

PRODUCT	PAG.
IECEX ATEX LINE	
Directive 2014/34/UE "ATEX"	128
Cabinets QL-EX	132
Small cabinets QLP-EX	136
Connectors DS-EX	138

6

IECEX ATEX LINE

IECEx ATEX LINE

Product line "ATEX"



In today's manufacturing, each processing stage can be a source of risks susceptible to explosions which, unless kept under control, can result in extensive injury to persons as well as in damage to the environment and the machinery. This risk exists in many companies in the chemical, petrochemical and pharmaceutical sector, where the production of potentially harmful gas-originated atmospheres can become extremely actual.

Not to be disregarded are also certain manufacturing conditions where the presence of fine organic powders from wood processing, light metal machining, in feed-stuff factories and in mills producing meals for the food industry can in turn produce the build-up of easily inflammable powders.

A strong sense of responsibility is required from all those who manufacture machinery or provide components engineered to operate on plants being classified as dangerous, in order to minimize the risks for human life.

To this effect, the regulations and directives in force at European and international level take into consideration the increased need for commitment to safety.

Directive 2014/34/UE "ATEX" (ATMOSPHERES EXPLOSIBLES)

The Directive is MANDATORY since 1st July 2003.

The Directive applies to protection Equipment or Systems designed to operate in areas exposed to the risk of explosion. "Equipment, means the machines, materials, fixed or mobile devices, controls, instruments and detection and prevention systems which, on their own or when combined, are intended for the production, transport, storage, measuring, adjustment, conversion of energy and for the transformation of materials that, due to their own specific potential priming sources, are at risk of causing explosion."

In order to be potentially explosive, there must be in the atmosphere the simultaneous presence of the three conditions of the so-called flame triangle.

PRIMING (flame, electric arc, hot body, impact, friction among surfaces)

COMBURENT (air, oxygen)

FUEL (gas, vapours, dusts, mists)

The priming conditions takes place when a specific mix occurs between comburent and fuel.

It is very important for the person in charge with the equipment operation to classify the area of installation, to make sure the materials used comply with the intended use.

The explosion-proofing requirements are quite demanding.

Ilinox containers meet these standards. Relentless research and development, pooled with a continuously expanding program, guarantee the connector blocks and the s/s boxes for areas Ex 1 and 2 with explosive gases and for areas EX 21 and 22 with explosive dusts.

The relevant conformity certificate compliant with Directive 2014/34/UE is available for all containers.

With long-lasting skill and utmost professional accuracy, Ilinox manufactures its enclosures exclusively from stainless steel, for complex and hazardous applications.

Great attention is paid mainly to Directives, laws and regulations having international validity and it is exactly within this frame that a key role is played by the close contact with engineering certifying Bodies.



GROUPS OF EQUIPMENT

GROUP	
I	Equipment intended for use in underground jobs in mines or in the relevant surface plants, exposed to the risk of firedamp burst and/or flammable powders.
II	Appliances intended for use in other environments where the presence of explosive atmospheres is possible.

GROUP II		
SUBSTANCE	AREA	DESCRIPTION
GAS "G"	0	Place where an explosive atmosphere formed by a mixture of air and flammable substances in the form of gas, vapour or mist is present either continuously or for long periods, or often (1.000 h/year at least).
	1	Place where an explosive atmosphere formed by a mixture of air and flammable substances in the form of gas, vapour or mist is present occasionally during routine operation (More than 10 , up to 1.000 h/year)
	2	Place where an explosive atmosphere formed by a mixture of air and flammable substances in the form of gas, vapour or mist is unlikely to occur during routine operation but, when present, only lasts shortly (NEVER longer than 10 h/year)
DUST "D"	20	Place where an explosive atmosphere in the form of a fog of a combustible dust is present in the air, either continuously, for long periods, or often.
	21	Place where an explosive atmosphere in the form of a fog of combustible dust is likely to occur occasionally during routine operation.
	22	Place where an explosive atmosphere in the form of a fog of combustible dusts in the air is unlikely to occur during routine operation but, when present, only lasts shortly. (NOT longer than 10 h/year)

CLASS OF THE EQUIPMENT	AREA	PROTECTION LEVEL	PROTECTION METHOD SERVICEABLE
1G	0	Very high	ia ÷ ma
2G	1	High	d ÷ e ÷ ib ÷ m ÷ o ÷ q ÷ p
3G	2	Standard	N
1D	20	Very high	IP6X
2D	21	High	IP6X
3D	22	Standard	IP6X (Conductor powders) IP5X (Non-conductor powders)

The protection method applied to higher classes can be applied to lower classes, too.

Protection methods

- Containment
- Prevention
- Insulation

Containment

The limitation of the explosion must permit to confine the explosion in a clearly defined place without propagation to the surrounding atmosphere. (d)

Prevention

The specificity of this method is to increase reliability of the electric components which, in routine operation, cannot make sparks nor reach surface temperatures capable of priming the explosive mixture. (ia ÷ ib ÷ e ÷ n)

Insulation

The specificity of this method is to physically separate or isolate the live electric components or hot surfaces from the explosive mixture, to prevent contact with the priming source. (p ÷ ma ÷ m ÷ o ÷ q)

Description of protection methods

ia ÷ ma	Inherent safety: use of components that cannot produce arcs or sparks.
ma ÷ m	Capping: closing the components into small tight caps.
d	Explosion-proofing: Closing the dangerous parts into strong cases thus limiting the explosion.
e	Increased safety: Take measures to avoid the formation of hot spots. Only for NON sparking equipment.
o	Immersion into oil: protection of the hazardous areas by dipping them into dielectric oil.
q	Under sand: filling static components with sand to isolate the hot spots from the atmosphere.
p	Inner overpressure: filling the cases with overpressurized inert gas to prevent hazardous atmosphere from entering.
n	<p>Simplified protection: Type A for NON sparking equipment, it consists in the application of the following increased safety criteria: Case protection degree IP54 or IP44 Unlosable gaskets, if any. Impact strength 1 ÷ 3,5 J Protection grid for fragile parts, mesh NOT more than 50x50 Monitoring of surface temperature</p> <p>Type B for SPARKLING equipment, it consists of the application of the increased safety criteria indicated for class A, limited venting with suitable gaskets and cable glands.</p>



For protection methods “d ” ÷ “i ” and, sometimes, “n ” three classifications exist as follows:
 II GA ÷ II GB ÷ II GC, the difference consisting in the type of gas present in the installation area.

The protection degree required for an higher class can apply also to lower ones.

Temperature Classes

The temperature class is related with the maximum temperature, which MUST NOT be overcome in the casings or the exposed hot spots, in case of any failure.

TEMPERATURE CLASS	T1	T2	T3	T4	T5	T6
Max Surface Temp. (°C)	450	300	200	135	100	85

ILINOX

has achieved the ATEX and “IECEx” certification for the connector blocks type DS and the Cabinets type QL - QLP with single and solid door.

The types mentioned above can be used in the electric protection type “eb”, “tb” (only for QL-EX and QLP-EX), “eb”, “ta” (only for DS-EX), or whenever the IP protection degree is the only tightness degree required.

The choice of the type of protection is always the Fitter’s responsibility.

Marking: enclosures are considered components, hence they DO NOT bear the CE MARK. Example of marking:

Marking for small cabinets QL and QLP



Marking for connector blocks DS



Our enclosures are fit for:

- Class 1D (area 20) for connector blocks Series DS-EX
- Class 2G (area 1) and 2D (area 21)

An higher approval covers the lower classes, as well, hence they are also fit for:

- Class 3G (area 2) and 3D (area 22)

For class 1G (area 0) the enclosure can be delivered with only the declaration of the IP degree and, possibly, a declaration for the materials employed, the validation procedure being at the charge of the Fitter of the equipment.

MARKING LEGEND

II	- Equipment Group
1- 2 - 3	- Equipment Class
G	- Fit for environments with presence of Gas
D	- Suitable for environments with presence of Dust (Explosive dusts)
U	- Identification of component status
EPT 18 ATEX 3029U	- Number of CE exam Certificate as issued by EUROFIN PRODUCT TESTING
IECEx EUT 18.0016 U	- Number of IECEx TR Certificate

Deliverables:

- a - Declaration of Conformity
- b - Use and Maintenance Manual
- c - Declaration of IP tightness (NOT mandatory)
- d - Declaration of materials employed in manufacturing (NOT mandatory)

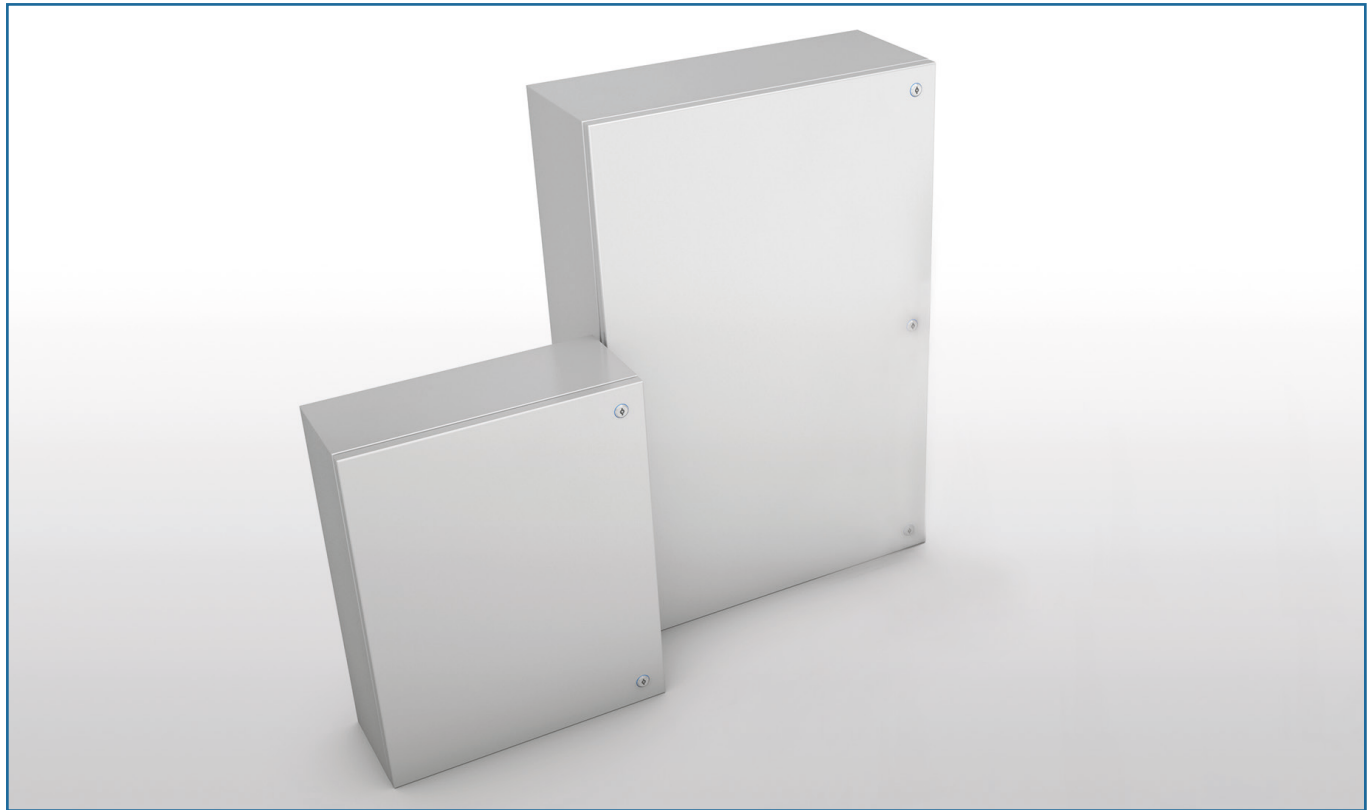

SMALL CABINETS SERIES QL - EX

- Material: stainless steel EN 1.4307 (TYPE 304L) or EN 1.4404 (TYPE 316L) scotch brite satin-finish and protection on one side.
- Enclosure obtained from a single sheet, shaped by multi-bending of the envelope front edge.
- Fairlead not included.
- Single full door.
- Locks: twin comb, standardized type Ø 3 for low voltage, s/s outer parts.
- S/s inner hinges: 120° opening as per CEI EN 60204-1 recommendations.
- Seal made of foamed polyurethane or silicone foam.
- The enclosure can be used under the following Maximum Temperatures on the outer surface: from -20°C to + 60°C with seal of bicomponent foamed polyurethan, from -40°C to + 180°C with seal of bicomponent silicone foam.
- Inner plate of EN 10142 sendzimir galvanized sheet, secured to the enclosure bottom by M8 threaded pins, delivered with the cabinet.
- Prearranged for earthing in compliance with the applicable regulations in force.
- Drillings, if any, to comply with the parameters indicated in the instruction manual.
- Protection degree: IP66 (CEI EN 60529).
- Certificates for areas 1 – 2 – 21 -22

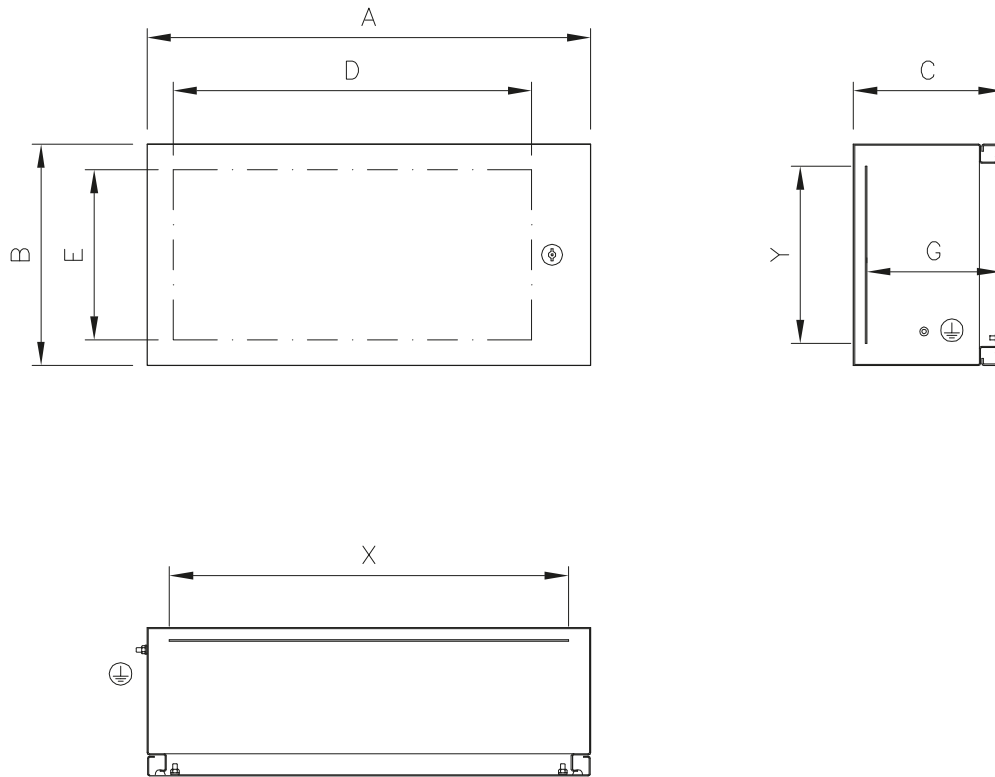

Ex II 2 GD IP66
IECEX EUT 18.0016 U
Ex eb IIC Gb
Ex tb IIIC Db
EPT 18 ATEX 3029 U
NB: 0477

UL US LISTED
FILE N° E237618

Detailed drawings per each cabinet can be downloaded from our site www.ilinox.com

ITEM	OUTSIDE SIZES			DOOR USEFUL SURFACE		USEFUL DEPTH G	MATERIAL		THICKNESS		INNER PLATE	
	A	B	C	D	E		GASKET	CABINET	ECLOSURE	DOOR	X	Y
QL33/304-EX	300	300	180	230	230	160	polyurethane	Type 304L	1,2 mm	1,5 mm	270	240
QL34/304-EX	300	450	200	230	380	180	polyurethane	Type 304L	1,2 mm	1,5 mm	270	390
QL43/304-EX	450	300	200	380	230	180	polyurethane	Type 304L	1,2 mm	1,5 mm	420	240
QL33S/316-EX	300	300	180	230	230	160	silicone	Type 316L	1,5 mm	1,5 mm	270	240
QL34S/316-EX	300	450	200	230	380	180	silicone	Type 316L	1,5 mm	1,5 mm	270	390
QL43S/316-EX	450	300	200	380	230	180	silicone	Type 316L	1,5 mm	1,5 mm	420	240

UL certification to be requested with the order

IECEx ATEX LINE

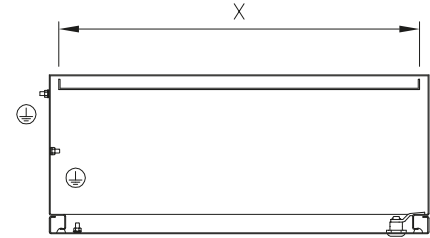
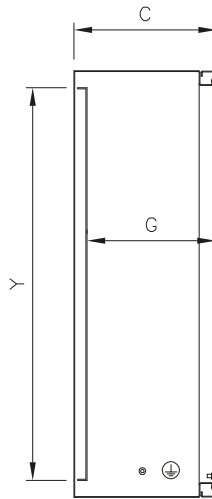
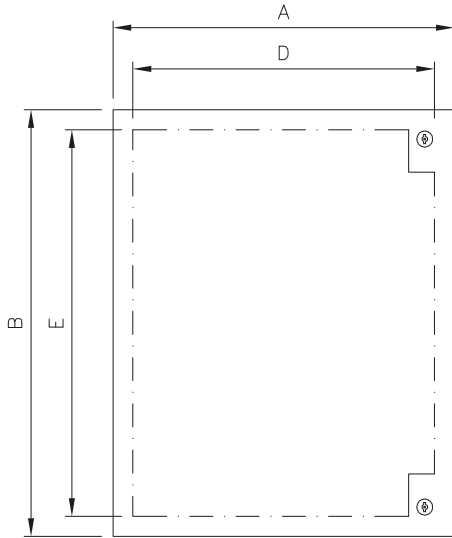

Ex II 2 GD IP66
IECEx EUT 18.0016 U
Ex eb IIC Gb
Ex tb IIIC Db
EPT 18 ATEX 3029 U
NB: 0477



Detailed drawings per each cabinet can be downloaded from our site www.ilinox.com

ITEM	OUTSIDE SIZES			DOOR USEFUL SURFACE		USEFUL DEPTH G	MATERIAL		THICKNESS		INNER PLATE	
	A	B	C	D	E		GASKET	CABINET	ECLOSURE	DOOR	X	Y
QL36/304-EX	300	600	250	230	530	230	polyurethane	Type 304L	1,2 mm	1,5 mm	270	540
QL44/304-EX	450	450	200	380	380	180	polyurethane	Type 304L	1,2 mm	1,5 mm	420	390
QL46/304-EX	450	600	250	380	530	230	polyurethane	Type 304L	1,2 mm	1,5 mm	420	540
QL46P/304-EX	450	600	400	380	530	380	polyurethane	Type 304L	1,5 mm	1,5 mm	420	540
QL64/304-EX	600	450	250	530	380	230	polyurethane	Type 304L	1,2 mm	1,5 mm	570	390
QL66/304-EX	600	600	250	530	530	230	polyurethane	Type 304L	1,2 mm	1,5 mm	570	540
QL66P/304-EX	600	600	300	530	530	280	polyurethane	Type 304L	1,2 mm	1,5 mm	570	540
QL66P4/304-EX	600	600	400	530	530	380	polyurethane	Type 304L	1,5 mm	1,5 mm	570	540
QL67/304-EX	600	750	250	530	680	230	polyurethane	Type 304L	1,5 mm	2 mm	570	690
QL68P/304-EX	600	800	400	530	730	380	polyurethane	Type 304L	1,5 mm	2 mm	570	740
QL69/304-EX	600	900	250	530	830	230	polyurethane	Type 304L	1,5 mm	2 mm	570	840
QL77/304-EX	750	750	300	680	680	280	polyurethane	Type 304L	1,5 mm	2 mm	720	690
QL710/304-EX	750	1000	300	680	930	280	polyurethane	Type 304L	1,5 mm	2 mm	720	940
QL86/304-EX	800	600	300	730	530	280	poliuretano	Type 304L	1,5 mm	2 mm	770	540
QL36S/316-EX	300	600	250	230	530	230	silicone	Type 316L	1,5 mm	1,5 mm	270	540
QL44S/316-EX	450	450	200	380	380	180	silicone	Type 316L	1,5 mm	1,5 mm	420	390
QL46S/316-EX	450	600	250	380	530	230	silicone	Type 316L	1,5 mm	1,5 mm	420	540
QL64S/316-EX	600	450	250	530	380	230	silicone	Type 316L	1,5 mm	1,5 mm	570	390
QL66S/316-EX	600	600	250	530	530	230	silicone	Type 316L	1,5 mm	1,5 mm	570	540
QL67S/316-EX	600	750	250	530	680	230	silicone	Type 316L	1,5 mm	2 mm	570	690
QL69S/316-EX	600	900	250	530	830	230	silicone	Type 316L	1,5 mm	2 mm	570	840
QL77S/316-EX	750	750	300	680	680	280	silicone	Type 316L	1,5 mm	2 mm	720	690
QL710S/316-EX	750	1000	300	680	930	280	silicone	Type 316L	1,5 mm	2 mm	720	940

UL certification to be requested with the order

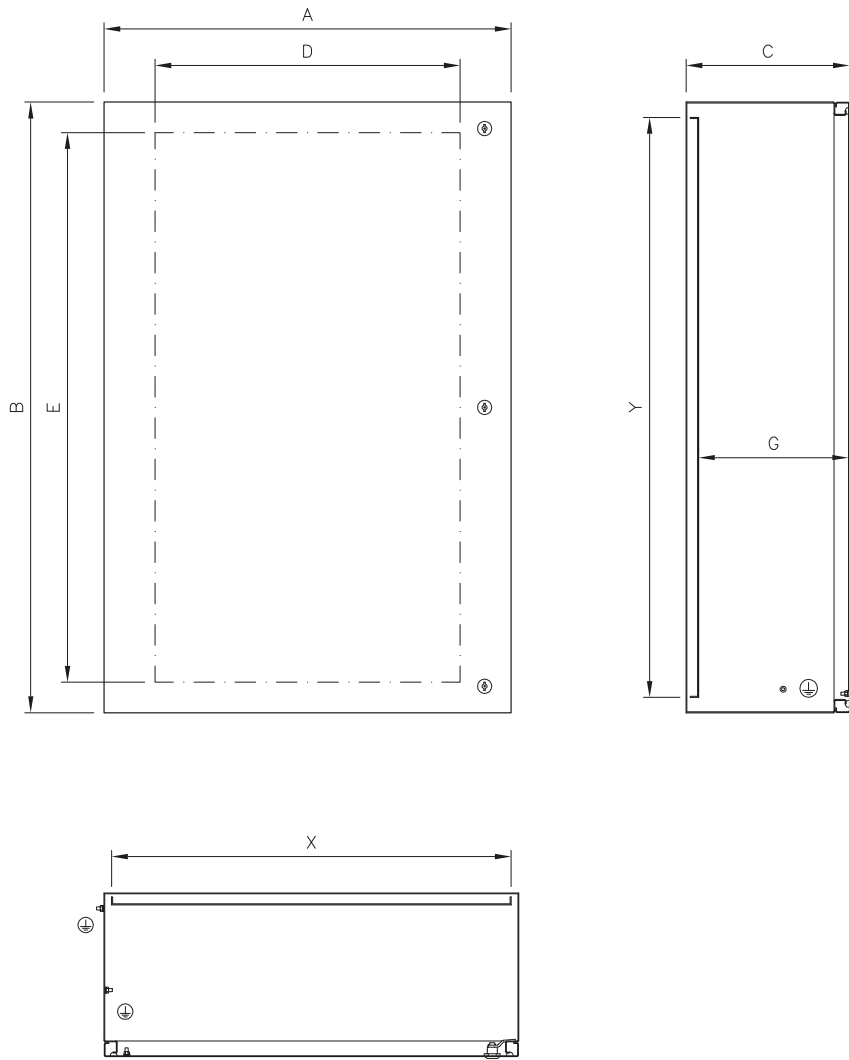

Ex II 2 GD IP66
IECEX EUT 18.0016 U
Ex eb IIC Gb
Ex tb IIIC Db
EPT 18 ATEX 3029 U
NB: 0477

UL US LISTED
FILE N° E237618

Detailed drawings per each cabinet can be downloaded from our site www.ilinox.com

ITEM	OUTSIDE SIZES			DOOR USEFUL SURFACE		USEFUL DEPTH	MATERIAL		THICKNESS		INNER PLATE	
	A	B	C	D	E	G	GASKET	CABINET	ECLOSURE	DOOR	X	Y
QL812/304-EX	800	1200	320	600	1080	300	polyurethane	Type 304L	1,5 mm	2 mm	770	1140
QL812S/304-EX	800	1200	320	600	1080	300	silicone	Type 304L	1,5 mm	2 mm	770	1140

UL certification to be requested with the order

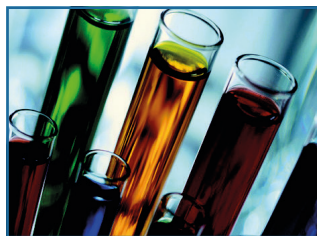
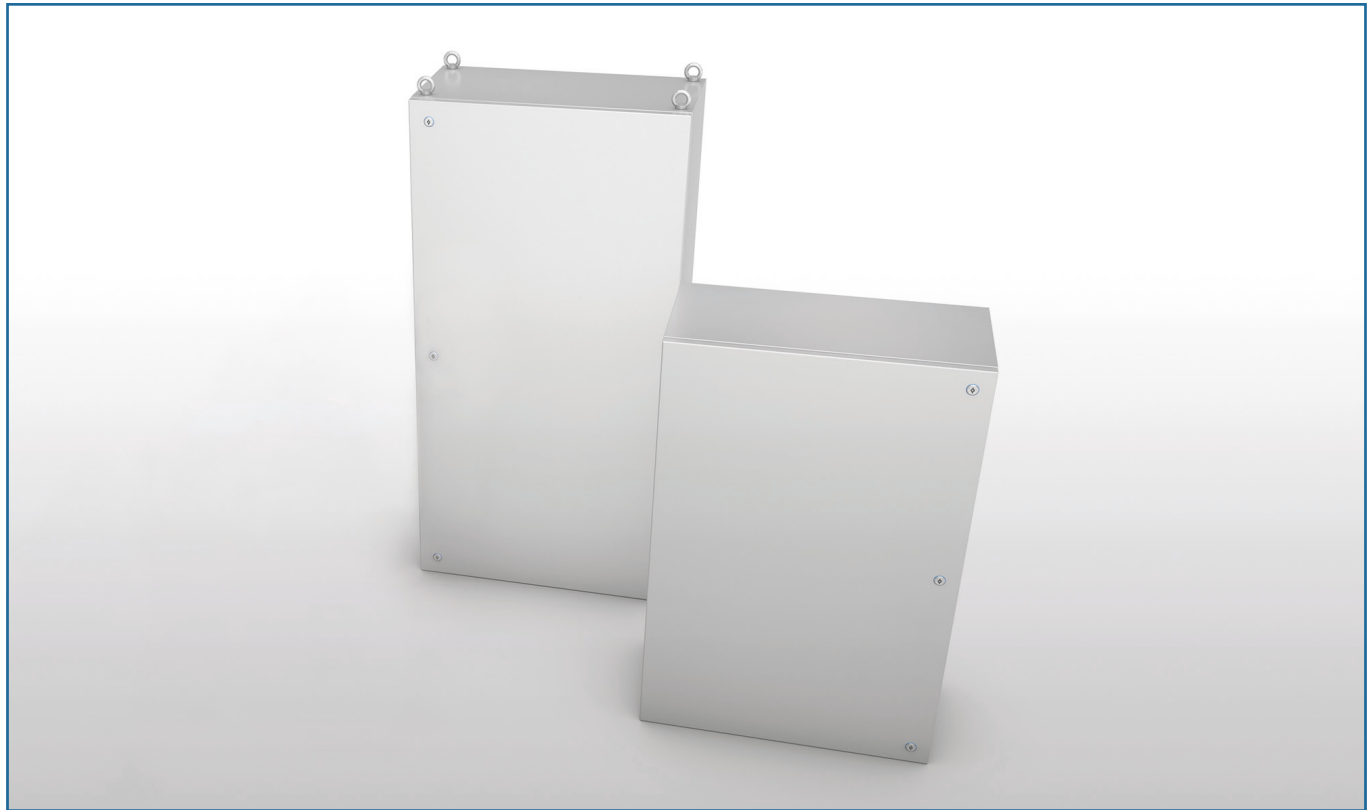

SMALL CABINETS SERIES QLP - EX

- Material: EN 1.4307 (TYPE 304L) s/s, scotch brite, satin-finish and protected on one side.
- Enclosure obtained from a single sheet, shaped by multi-bending of the enclosure front edge.
- Door Locks: twin-comb mapping, standardized type Ø 3 for Low Tension, s/s outside parts.
- S/s inner hinges: 120° opening as per CEI EN 60204-1 recommendations.
- Seal made of foamed polyurethane or silicone foam.
- The enclosure can be used at the following Maximum Temperatures on the outer surface: from -20°C to + 60°C with seal of bi-component foamed polyurethane from -40°C to + 180°C with seal of bi-component silicone foam.
- Inner plate: EN 10142 sendzimir galvanized sheet execution, secured to the bottom of the enclosure by M8 threaded pins delivered with the enclosure.
- Prearranged for earthing in compliance with the applicable regulations in force.
- Drillings, if any, to comply with the parameters indicated in the instruction manual.
- Protection degree: IP66 (CEI EN 60529).
- Certificates for areas 1 – 2 – 21 -22
- Fairlead not provided.

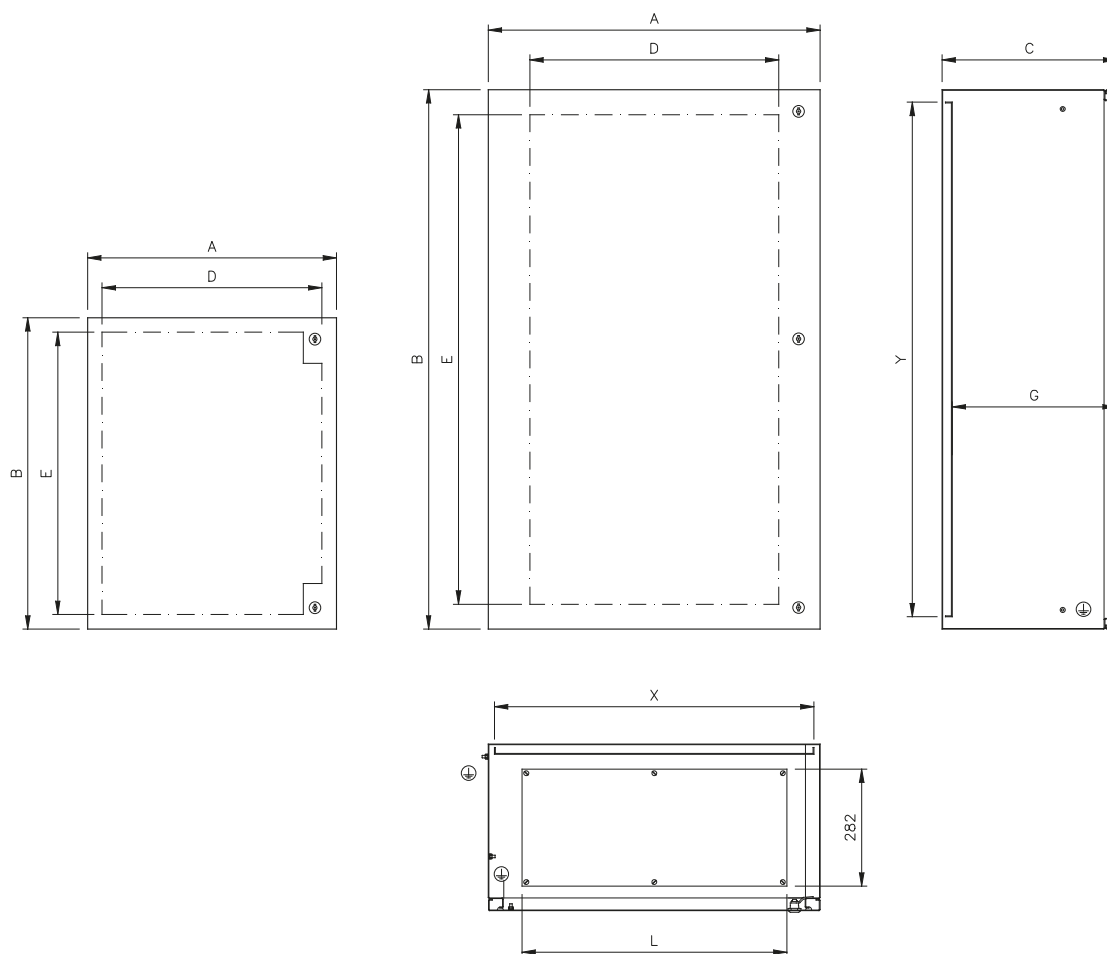

 II 2 GD IP66
 IECEx EUT 18.0016 U
 Ex eb IIC Gb
 Ex tb IIIC Db
 EPT 18 ATEX 3029 U
 NB: 0477

 US LISTED
 FILE N° E237618

Detailed drawings per each cabinet can be downloaded from our site www.ilinox.com

ITEM	OUTSIDE SIZES			DOOR USEFUL SURFACE		USEFUL DEPTH	MATERIAL		THICKNESS		INNER PLATE		CABLE WAY
	A	B	C	D	E	G	GASKET	CABINET	ECLOSURE	DOOR	X	Y	L
QLP612-EX	600	1200	400	530	1130	380	polyurethane	Type 304L	1,5 mm	2 mm	570	1140	422
QLP616-EX	605	1600	400	400	1460	372	polyurethane	Type 304L	1,5 mm	2 mm	521	1521	422
QLP812-EX	800	1200	400	600	1080	380	polyurethane	Type 304L	1,5 mm	2 mm	770	1140	622
QLP816-EX	805	1600	400	600	1480	372	polyurethane	Type 304L	1,5 mm	2 mm	721	1521	622
QLP612S-EX	600	1200	400	530	1130	380	silicone	Type 304L	1,5 mm	2 mm	570	1140	422
QLP616S-EX	605	1600	400	400	1460	372	silicone	Type 304L	1,5 mm	2 mm	521	1521	422
QLP812S-EX	800	1200	400	600	1080	380	silicone	Type 304L	1,5 mm	2 mm	770	1140	622
QLP816S-EX	805	1600	400	600	1480	372	silicone	Type 304L	1,5 mm	2 mm	721	1521	622

NOTES: QLP612 - QLP812 : three doorlocks
 QLP616 - QLP816 : three doorlocks, hoisting eyebolts.

UL certification to be requested with the order

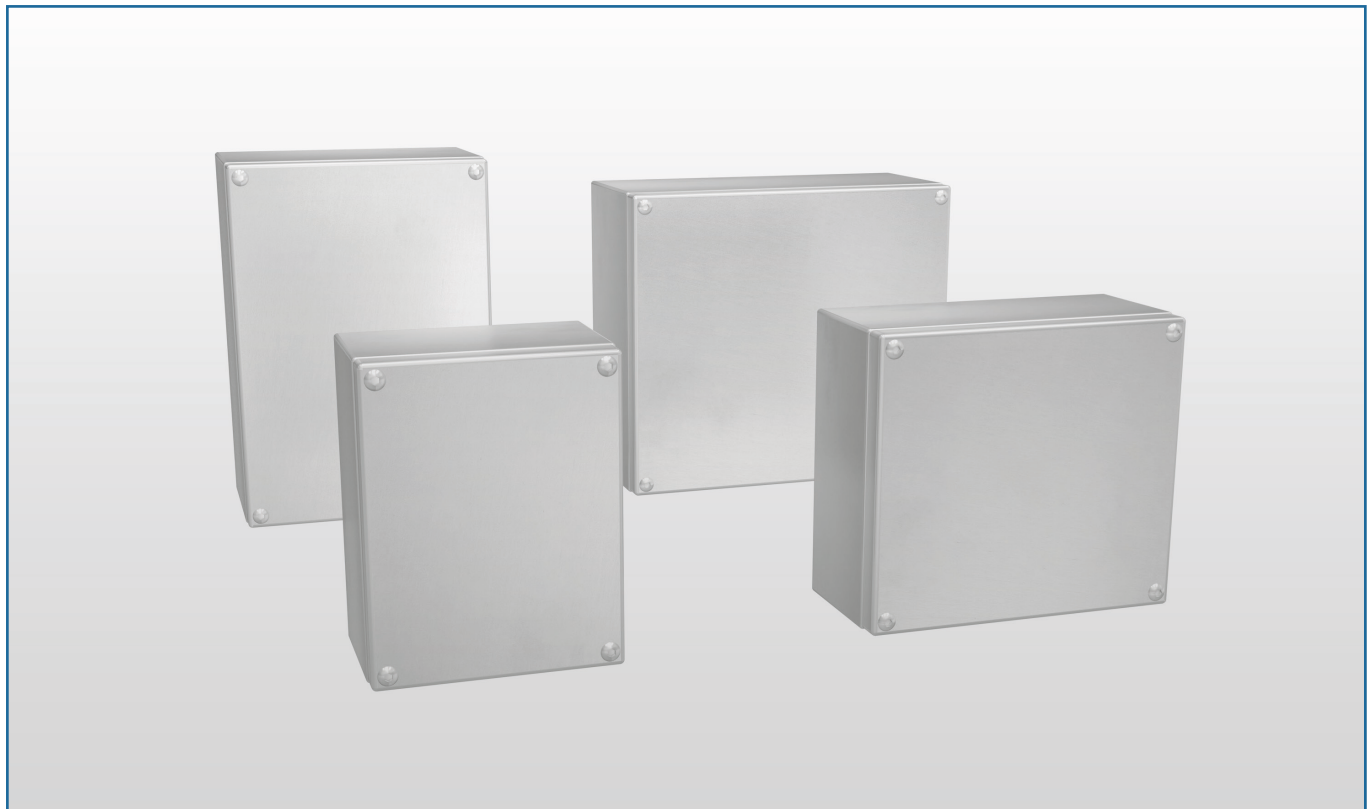

CONNECTOR BLOCKS DS - EX

- Made of EN 1.4307 (TYPE 304L) or EN 1.4404 (TYPE 316L) s/s, scotch brite, satin-finish, protected on one side.
- The state-of-the-art welding methods adopted permit to maintain unaltered the chemical composition of the material, thus avoiding corrosion phenomena in the weld areas.
- The cover is secured by special "leak-proof" screws M5.
- Seal made of silicone foam.
- The enclosure can be used at the following Maximum Temperatures on the outer surface: from -40°C to + 180°C.
- Pre-arranged for earthing in compliance with the applicable regulations in force.
- S/s stud bolts M6 are set to the bottom to secure bars and structural sections.
- Inner plate in sendzimir execution (on request).
- Drillings, if any, are possible in compliance with the parameters indicated in the instruction manuals.
- Protection degree IP66 (CEI EN 60529).
- Certificates for area 1 – 2 – 20 - 21 -22

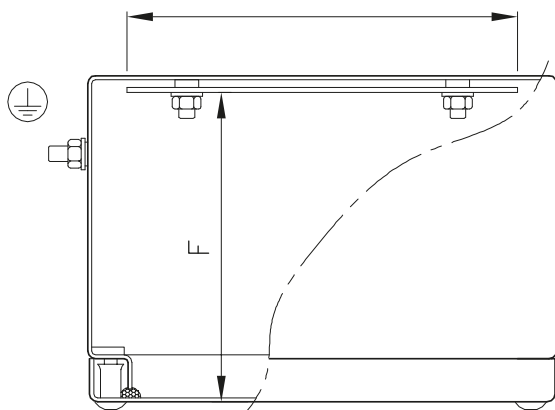
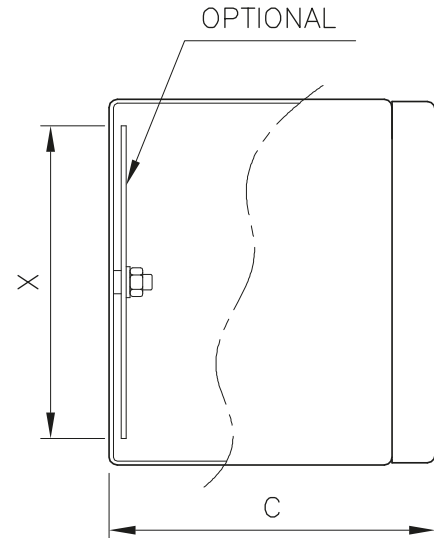
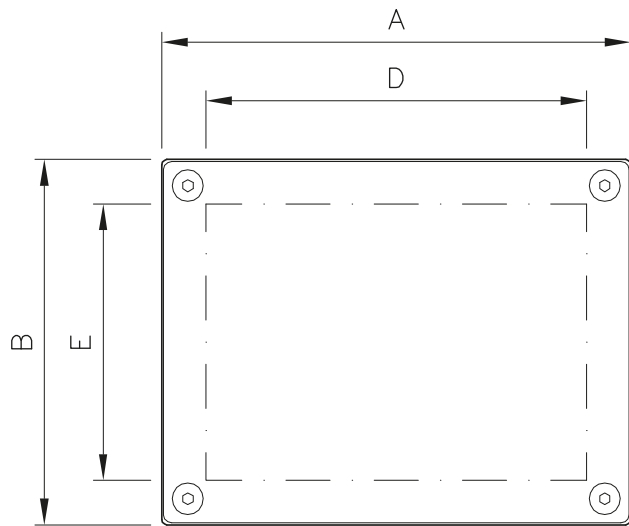

Ex II 1D 2G IP66
IECEx EUT 18.0016 U
Ex eb IIC Gb
Ex ta IIIC Da
EPT 18 ATEX 3029 U
NB: 0477



Detailed drawings per each cabinet can be downloaded from our site www.ilinox.com

ITEM	OUTSIDE SIZES			USEFUL SURFACES			MATERIAL			INNER PLATES (OPTIONAL)		
	A	B	C	D	E	F	GASKET	TYPE	THICKNESS	ITEM	X	Y
DS009/304-EX	210	190	125	170	150	118	silicone	Type 304L	1,2 mm	PI009	192	150
DS012/304-EX	270	190	125	230	150	118	silicone	Type 304L	1,2 mm	PI012	252	150
DS016/304-EX	270	240	125	230	200	118	silicone	Type 304L	1,2 mm	PI016	252	200
DS020/304-EX	320	230	150	280	190	143	silicone	Type 304L	1,2 mm	PI020	280	190
DS025/304-EX	320	280	150	280	240	143	silicone	Type 304L	1,2 mm	PI025	280	240
DS043/304-EX	400	300	150	360	260	143	silicone	Type 304L	1,2 mm	PI043	360	260
DS006/316-EX	190	150	125	150	110	118	silicone	Type 316L	1,5 mm	PI006	172	110
DS010/316-EX	210	210	125	170	170	118	silicone	Type 316L	1,5 mm	PI010	192	170
DS012/316-EX	270	190	125	230	150	118	silicone	Type 316L	1,5 mm	PI012	252	150
DS016/316-EX	270	240	125	230	200	118	silicone	Type 316L	1,5 mm	PI016	252	200
DS020/316-EX	320	230	150	280	190	143	silicone	Type 316L	1,5 mm	PI020	280	190
DS025/316-EX	320	280	150	280	240	143	silicone	Type 316L	1,5 mm	PI025	280	240
DS040/316-EX	400	200	150	360	160	143	silicone	Type 316L	1,5 mm	PI040	360	160
DS060/316-EX	600	200	150	550	150	143	silicone	Type 316L	1,5 mm	PI060	565	152

NOTES: from DS006 to DS016 no. 2 studbolts to secure the DIN bar or the inner plate
from DS020 to DS060 no. 4 studbolts to secure the inner plate

UL certification to be requested with the order

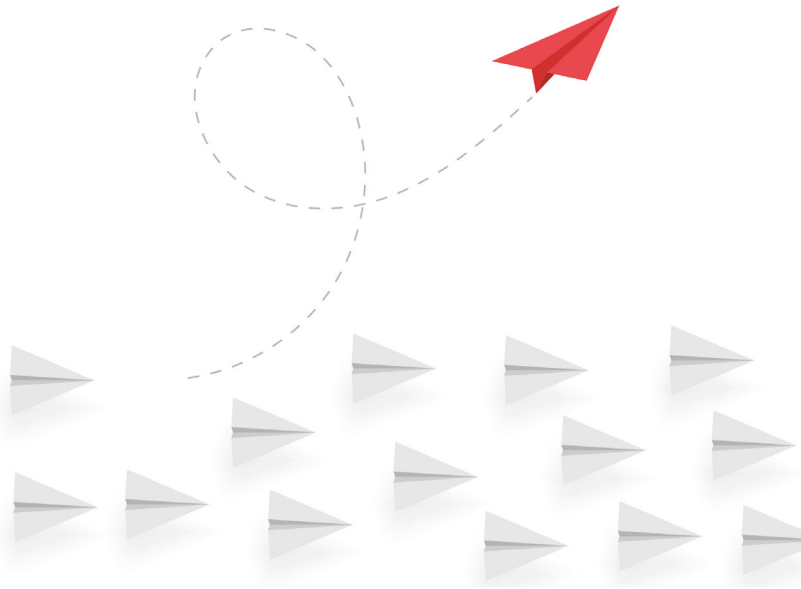

Think different! Our after-sale follow-up makes the difference.

**Advice before, during and after purchase.
For all your requirements, ilinox is there.**

Through our agents present all over the national territory and the companies represented in the major European towns, inhouse trained skilled personnel, on call every day, to ensure you an accurate pre-sale advice and a timely solution to any problems. Each technician is a great expert of our products.