

Fire protection solutions for the railway industry

Certified safety in cable management that exceeds standards

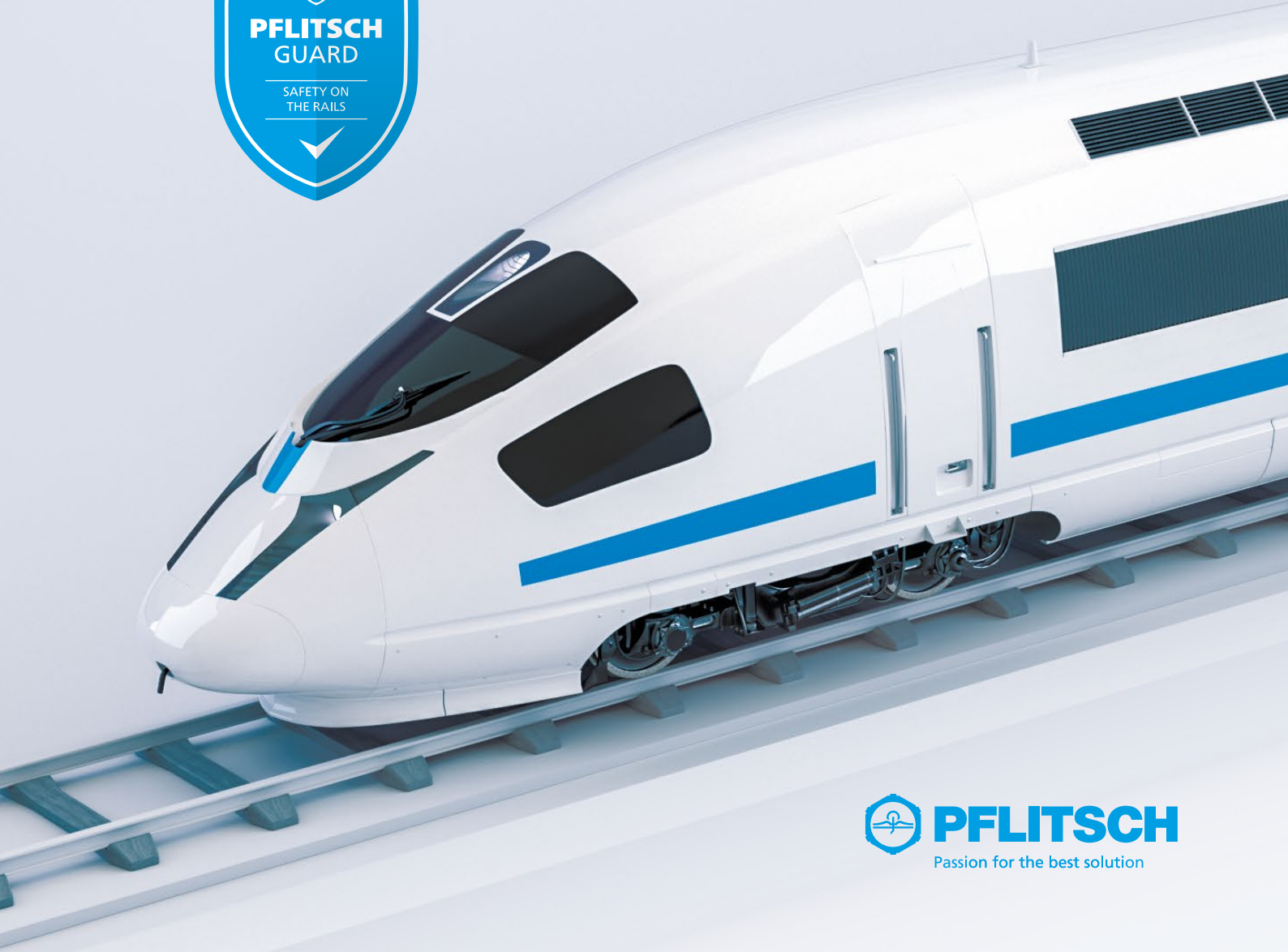

Certified safety for rail vehicles

For many years, PFLITSCH has been a trusted partner of the railway industry when it comes to cable entries, cable routing and cable protection, both inside and outside vehicles. That's why major train, component and systems manufacturers use solutions from PFLITSCH.

The added value provided by PFLITSCH products: Not only are they certified to current fire protection standards for rail vehicles such as EN 45545, they are also known for their impressive tightness of seal, robustness, durability and ease of assembly.

This attractive bundle of advantages is possible because we include large 'safety cushions' in our development and material selection processes.

For example: In the fire barrier or 'integrity' test, the protection level offered by blueglobe and UNI Dicht cable glands is consistently 30 minutes, which is twice as long as the relevant standard demands.

So PFLITSCH solutions give you the certainty of always being on the safe side.



PFLITSCH GUARD

Our portfolio comprises systems for cable entries, cable routing and cable protection. These are optimally coordinated across the product categories and stand for the highest levels of quality and reliability. That's why we can make you our PFLITSCH GUARD promise with a clear conscience:

All our solutions provide your machines and plant with maximum safety in all applications they have been designed for – and give you the reassuring feeling that you have made the right choice.



EN 45545

To standardise fire protection requirements across Europe, regulators introduced the **EN 45545** standard, which also enjoys high standing all round the globe.



There are many aspects to safety in rail vehicles. PFLITSCH solutions reflect them all.

The issue of safety in rail vehicles is extremely wide-ranging and complex – after all, passenger protection enjoys absolute priority. It's not without reason that the highest demands are placed on the materials – on complete vehicles as well as on individual components and systems. As a long-standing market player and pioneer in the

field of fire protection solutions for the railway industry, we are very familiar with the business and, thanks to our development, consulting and planning expertise, are able to come up with solutions that are precisely tailored to the respective specifications in every respect.

What you require



... for fire protection

- » Fire protection products must be certified for use around the globe
- » The probability of a fire breaking out should be minimized
- » Fire spread must be restricted
- » The release of harmful smoke and gases must be kept to a minimum

... for technical properties

- » Durable and robust cable glands
- » Optimal level of protection for every application: power cables, data lines, hoses and corrugated conduits – especially with regard to tightness, UV and weathering resistance, and EMC
- » Quick, easy assembly and maintenance
- » Full range



What you get from us

» PFLITSCH GUARD:

Our promise for railway-specific fire protection solutions designed from the ground up

» **Full range** of fire protection cable glands in sizes M12 to M63 designed especially for the railways, including EMC solutions. Useful accessories such as cable trunking, pressure equalisation elements and time-saving special tools complete the product range

» **Uniformly high standard of fire protection** for HL2 or HL3 according to EN 45545-2 and fire barrier test in line with EN 45545-3

» Exceeding of standards:

In the fire barrier test in line with EN 45545-3, PFLITSCH cable glands achieve the fire integrity classification E30

» Manufacturers' and association standards:

Bombardier SMP 800 and NFPA

» International certificates:

VDE, CSA and UL

» High-quality materials for safety and low total costs over the entire life cycle:

Maximum reliability, robustness and durability outdoors and indoors, thanks to the use of, e.g. TPE and high temperature-resistant silicone for the sealing inserts

» Excellent tightness of seal up to IP 68/IP 69

» Above-average strain relief

» **Protection** from mechanical wear such as stone chipping and vibrations

» Time- and cost-saving assembly



When super-stringent standards are the norm – PFLITSCH fire protection solutions

The two essential fire protection criteria in trains are to control the spread of smoke and fire and to contain the development of harmful smoke and gases. A number of norms and standards cover this.

Among the most important are the globally recognised standards EN 45545-2 covering material testing and EN 45545-3, Fire resistance requirements for fire barriers.

Within the scope of these tests, the cable glands and sealing inserts are thoroughly tested. EN 45545-2 regulates testing of the oxygen concentration, smoke density and toxicity of the sealing inserts in a fire. EN 45545-3 on the other hand is concerned with how long a cable gland is capable of withstanding fire.

In both sets of tests, the fire protection solutions from PFLITSCH meet the necessary requirements; in the case of the fire barrier or 'integrity' test, they even withstand the fire for twice as long as required.

In the fire barrier test, the cable glands even withstand the fire for twice as long as required.

In addition to the legal standards, there are also manufacturer- and association-specific standards that have a high priority.

Bombardier standard SMP 800

The French Bombardier standard SMP 800 is designed to test the level of toxic vapours emitted by the sealing inserts of cable glands in the event of fire. **The two PFLITSCH sealing inserts T80s and S55 are both well below the threshold values.**

NFPA standard

The US NFPA standard is also important. The tests examine properties such as heat development and visible smoke release rates. We had these properties tested for **our T80s and S55 sealing inserts: Both passed with flying colours.**

The right solution for every application – whether on open stretches of track, in tunnels or in stations

Cable gland	Material properties in accordance with EN 45545-2 material testing of sealing inserts		"Integrity" fire resistance test in accordance with EN 45545-3	
	TPE T80s (standard)	Silicone S55 (high-temp.)	TPE T80s (standard)	Silicone S55 (high-temp.)
blueglobe brass	HL3	HL3	✓	✓
blueglobe polyamide	HL3	HL3	✓	
UNI Dicht brass	HL3	HL3	✓	✓
UNI Dicht polycarbonate	HL2	HL2		
UNI flange polyamide	HL3	–	✓	
UNI flange HD zinc die casting	HL3	–	✓	
UNI Split Gland polycarbonate	HL2	–	✓	

PFLITSCH – the right solutions for all train applications

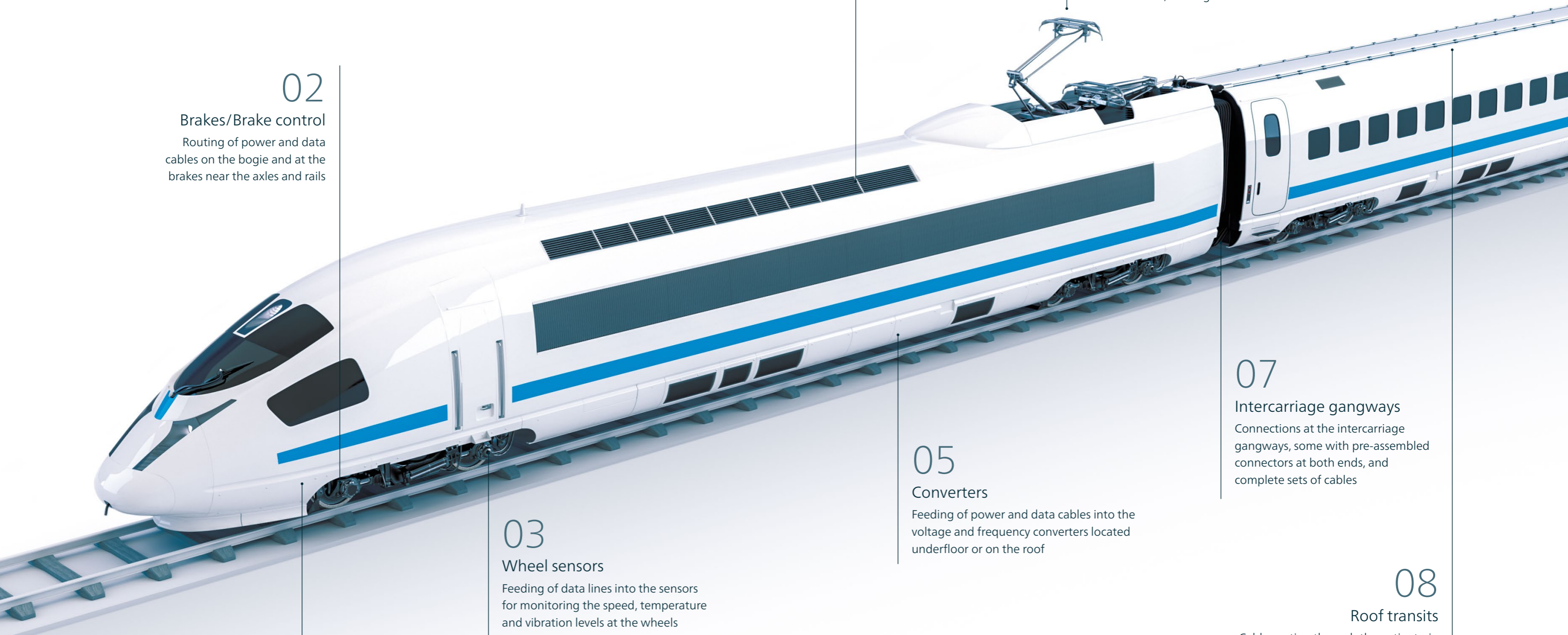

02

Brakes/Brake control

Routing of power and data cables on the bogie and at the brakes near the axles and rails

03

Wheel sensors

Feeding of data lines into the sensors for monitoring the speed, temperature and vibration levels at the wheels

01

Traction motors

In the traction motors of the powered bogies in the underfloor area

04

Air-conditioning units

Feeding of power and data cables into air-conditioning units – for small systems in the driver’s cab and large systems for the passenger compartment on the roof of the carriage

06

Pantographs

Routing of corrugated conduits with cables through the roof of the train, feeding of cables into control units

05

Converters

Feeding of power and data cables into the voltage and frequency converters located underfloor or on the roof

07

Intercarriage gangways

Connections at the intercarriage gangways, some with pre-assembled connectors at both ends, and complete sets of cables

08

Roof transits

Cable routing through the entire train with special, customised solutions

PFLITSCH fire protection solutions – seamless safety in all components

Cable glands are an essential part of the overall safety concept of a rail vehicle if reliable and seamless fire protection is to be achieved. Because the primary objective is that each and every component helps to prevent or limit a fire. In addition to the required fire protection properties, PFLITSCH fire protection cable glands also impress in terms of cost efficiency:

thanks to above-average durability and cost- and time-saving assembly and maintenance, you can count on the total cost of ownership being low.

You can see how our systems are put to use in the various components on the following pages.



blueglobe cable gland

blueglobe: top-notch for tightness of seal and strain relief

PFLITSCH's blueglobe cable gland with the black spherical sealing insert ensures a reliable seal over a large area, an excellent IP protection rating and a high degree of strain relief. For reliable EMC shielding into the GHz range, we

offer the blueglobe TRI. The PFLITSCH blueglobe is available in nickel-plated brass, stainless steel or polyamide (PA).

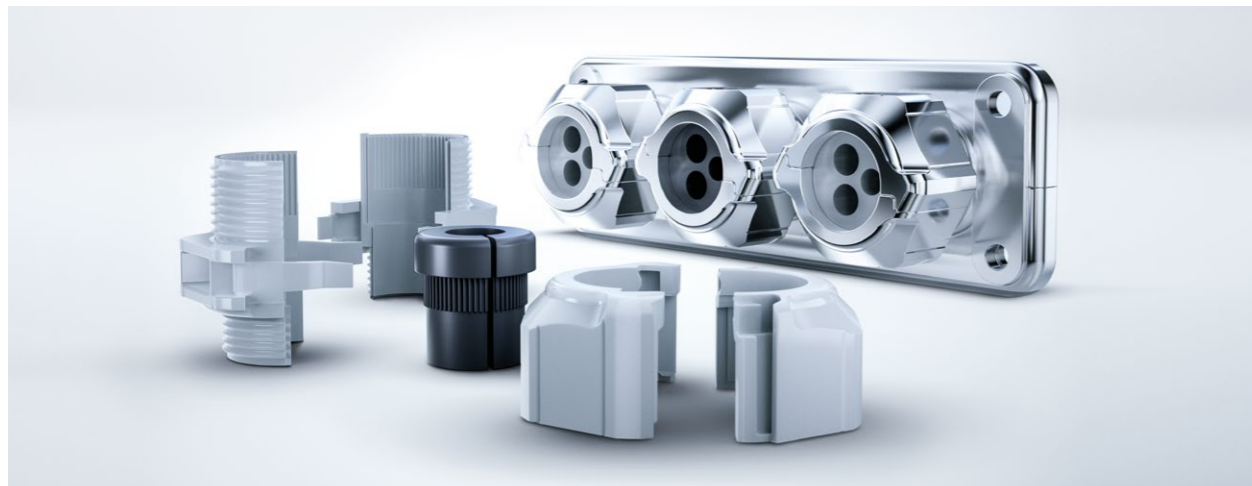

Fully splittable – UNI Split Gland and UNI flange HD

Split systems: simple and versatile

Feeding preassembled cables into an enclosure can be time-consuming. But it doesn't have to be – thanks to the UNI Split Gland and UNI flange systems from PFLITSCH.

These are equipped with special slit fire protection

sealing inserts, which are available as single and multiple variants. The UNI Split Gland is available in polycarbonate and die-cast zinc versions, while the UNI flange can be had in polyamide (PA) or die-cast zinc.

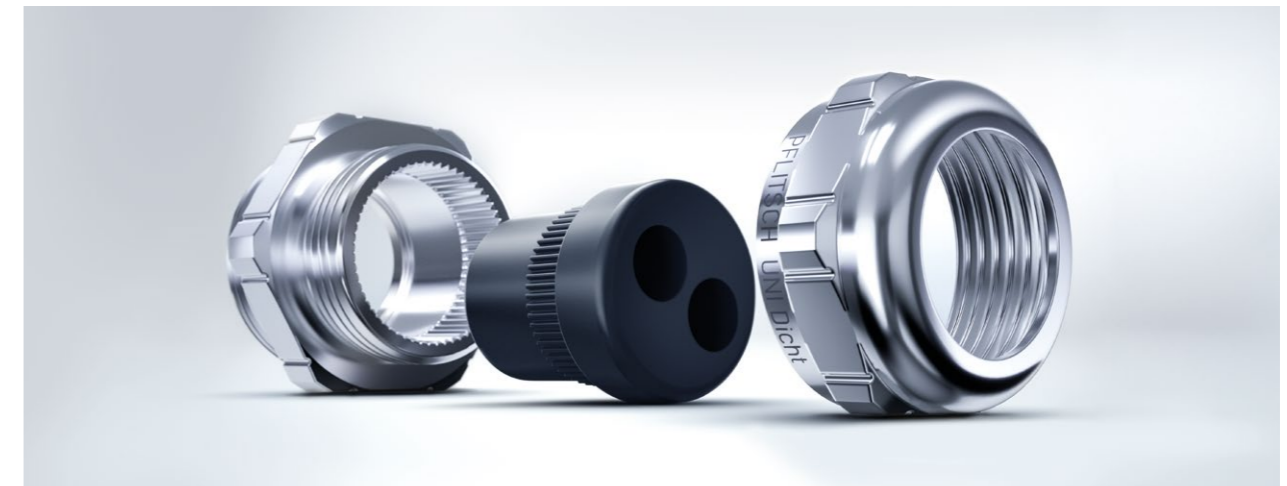

UNI Dicht cable gland with multiple sealing insert

UNI Dicht: always the right solution

The UNI Dicht system comprises a wide range of components that always allow you to put together the right solution for your needs. At the same time, you benefit from high protection ratings, dependable operational

safety and optional EMC shielding.

The UNI Dicht is available in nickel-plated brass, stainless steel or polycarbonate (PC) – with standard and multiple sealing inserts.

01 | How we make powerful drive motors safer

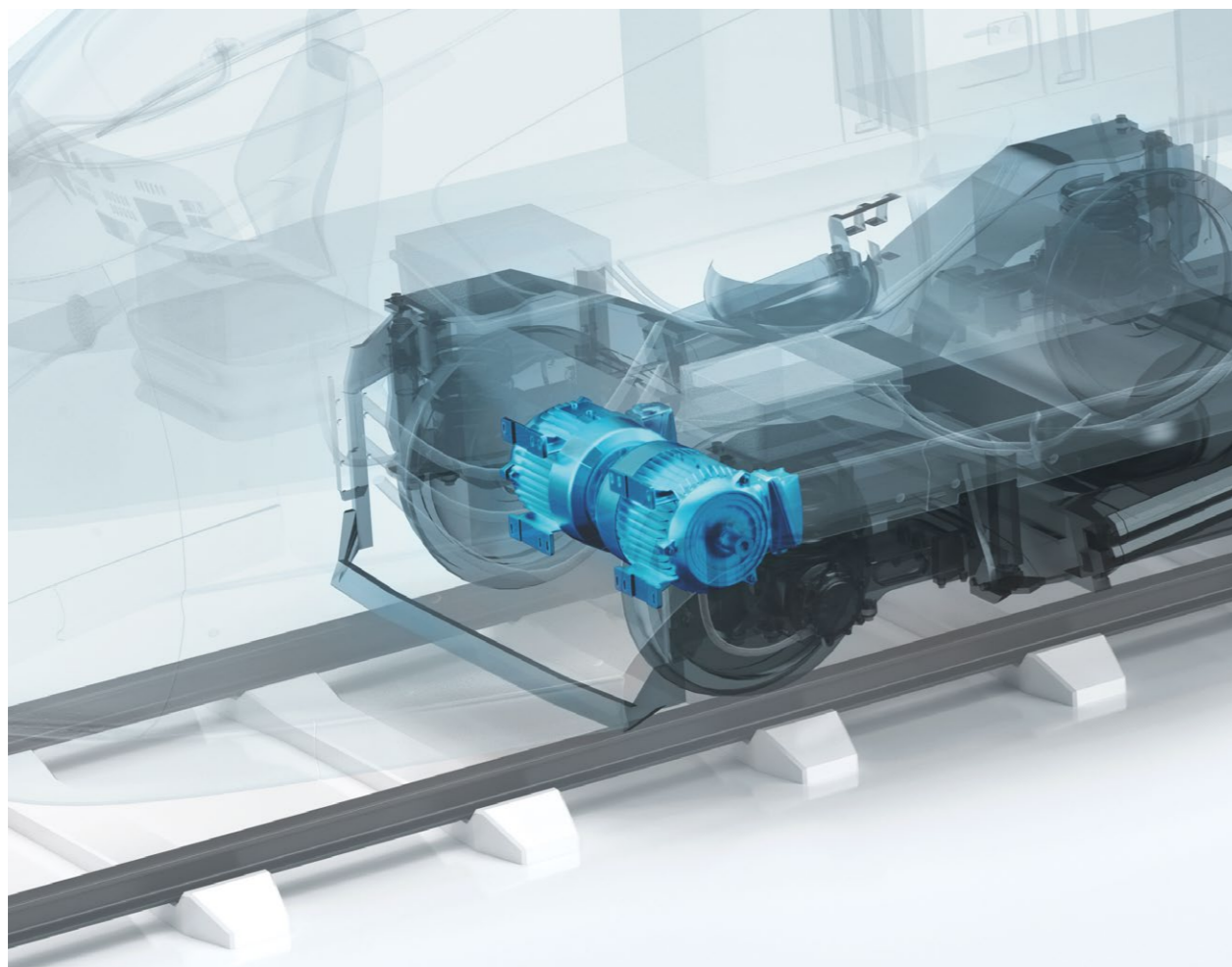

Our product solutions

- » Fire protection cable glands certified for use all around the world
- » Made of nickel-plated brass or stainless steel
- » Temperature range: -55 °C to +180 °C
- » Also available as variant with EMC shielding
- » IP 68 up to 10 bar



UNI Dicht fire protection cable gland with sealing insert made of T80s

Material	Nickel-plated brass or AISI 303 (1.4305) stainless steel
Sizes	M12 to M63 (other sizes and long connection thread available)
Type of protection	IP 68 up to 10 bar, Type 4x
Temperature range	-40 °C to +130 °C



UNI EMC Dicht fire protection cable gland with sealing insert made of T80s

Material	brass, nickel-plated
Sizes	M16 to M50 (other sizes available)
Type of protection	IP 68 up to 10 bar
Temperature range	-40 °C to +130 °C (S55 sealing insert on request)
Special feature	Also available as an EMC variant.



What you require

- » The power and data cables for the traction motors in the powered bogies in the underfloor area are subject to very high stress levels
- » Long-term tightness of seal must be ensured
- » Reliable protection against mechanical stresses such as stone chipping
- » Vibration resistance is mandatory
- » Depending on the application, EMC shielding is required

02 | Our solutions for fail-safe brakes

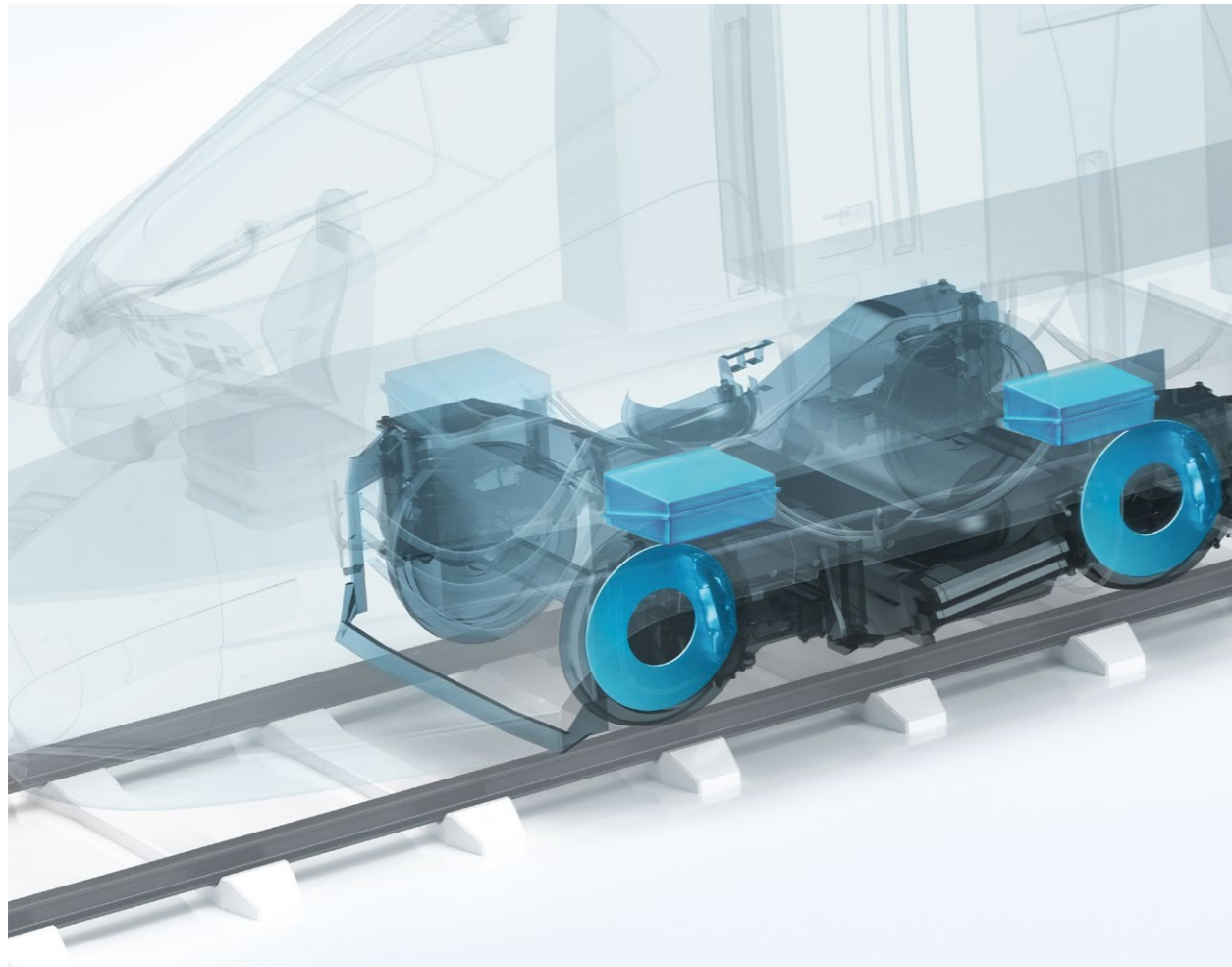

Our product solutions

- » Fire protection cable glands certified for use all around the world
- » Cable glands for individual cables, for corrugated conduits and for hydraulic lines – a product range for the entire brake system
- » Made of nickel-plated brass or stainless steel, with sealing inserts made of TPE or silicone; the corrugated conduit components are made of polyamide
- » Temperature range: -55 °C to +180 °C
- » IP 68: protection up to water pressure of 10 bar

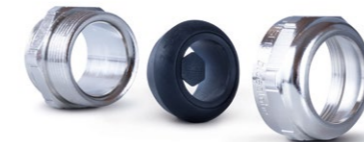

Image similar to product – the pressure screws are sheathed with PA in order to aid routing of the corrugated conduits

UNI Dicht fire protection cable gland with PMA cap (PMAFIX) for medium-sized corrugated conduit

Material	Nickel-plated brass, fitting and corrugated conduit made of PA
Sizes	M16 to M63
Type of protection	IP 68
Temperature range	-40 °C to +105 °C

blueglobe fire protection cable gland with sealing insert made of S55 or T80s



Material	Nickel-plated brass or AISI 303 (1.4305) stainless steel (All versions also available with long connection thread)
Sizes	M12 to M63 (M16 to M32 available with long connection thread)
Type of protection	IP 68 up to 15 bar
Temperature range	-55 °C to +180 °C (S55), -40 °C to +130 °C (T80s)

UNI Dicht fire protection cable gland with sealing insert made of S55 or T80s



Material	Nickel-plated brass or AISI 303 (1.4305) stainless steel
Sizes	M12 to M63 (other sizes and long connection thread available)
Type of protection	IP 68 up to 10 bar, Type 4x
Temperature range	-55 °C to +180 °C (S55), -40 °C to +130 °C (T80s)



What you require

- » Safe routing of power cables, data lines, hoses and corrugated conduits on the bogie near the axles and rails
- » Vibration resistance
- » Wide temperature range
- » Strain relief
- » Weather resistance
- » Mechanical protection against stone chipping

03 | Wheel sensors – and how our products make them more reliable

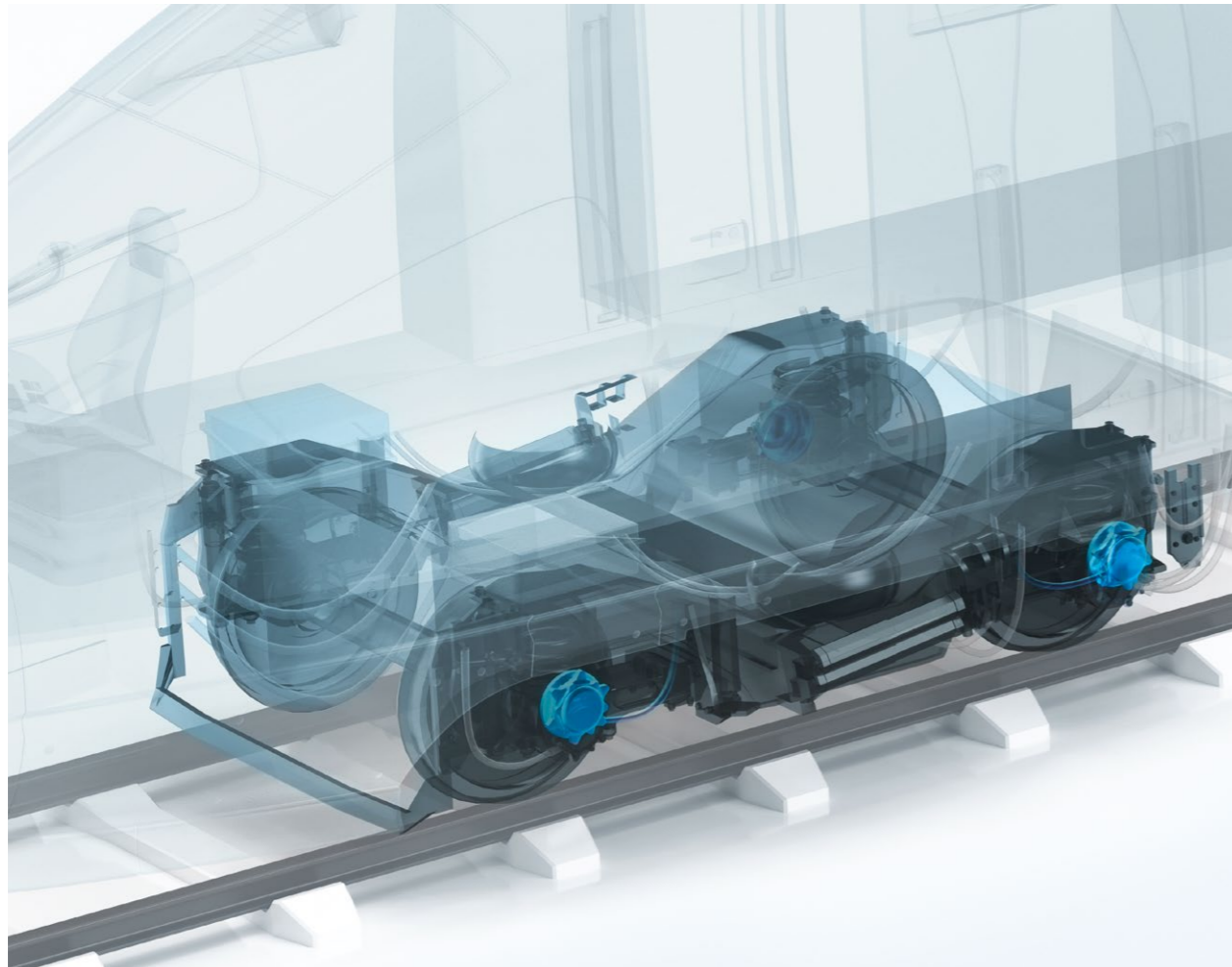

Our product solutions

- » Fire protection cable glands certified for use all around the world
- » The temperature resistance of the cable glands is greater than that of the sensors
- » IP 68



blueglobe fire protection cable gland with sealing insert made of S55 or T80s

Material	Nickel-plated brass or AISI 303 (1.4305) stainless steel (All versions also available with long connection thread)
Sizes	M12 to M63 (M16 to M32 available with long connection thread)
Type of protection	IP 68 up to 15 bar
Temperature range	-55 °C to +180 °C (S55), -40 °C to +130 °C (T80s)



UNI Dicht fire protection cable gland with sealing insert made of S55 or T80s

Material	Nickel-plated brass or AISI 303 (1.4305) stainless steel
Sizes	M12 to M63 (other sizes and long connection thread available)
Type of protection	IP 68 up to 10 bar, Type 4x
Temperature range	-55 °C to +180 °C (S55), -40 °C to +130 °C (T80s)



What you require

- » Robust feed-in of the data lines of speed, temperature and vibration sensors at the wheels
- » Weather resistance:
- » Vibration resistance
- » Wide temperature range

04 | Increase the operational reliability of air-conditioning units – with PFLITSCH solutions

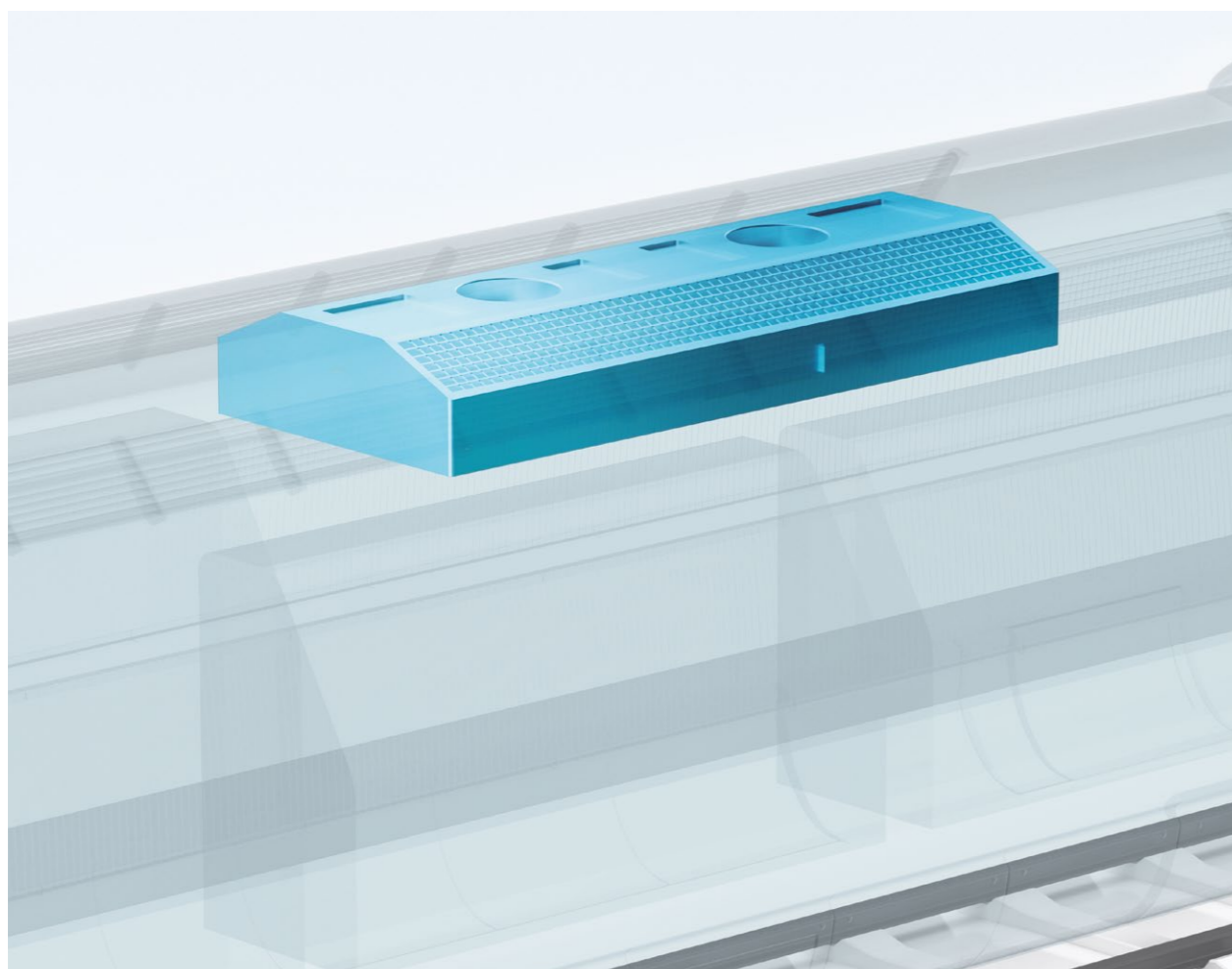

Our product solutions

- » Fire protection cable glands certified for use all around the world
- » Freedom in the choice of material: nickel-plated brass, stainless steel or plastic (PA/PC)
- » Sealing insert made of S55 for applications subject to extreme stresses

- » Single and multiple sealing inserts made of silicone and T80s
- » Temperature range: -55 °C to +180 °C
- » IP 68 up to 10 bar

UNI Dicht fire protection cable gland with sealing insert made of S55 or T80s



Material	Nickel-plated brass or AISI 303 (1.4305) stainless steel
Sizes	M12 to M63 (other sizes and long connection thread available)
Type of protection	IP 68 up to 10 bar, Type 4x
Temperature range	-55 °C to +180 °C (S55), -40 °C to +130 °C (T80s)

UNI Multiple fire protection cable gland with T80s sealing insert



Material	Nickel-plated brass or AISI 303 (1.4305) stainless steel
Sizes	M16 to M63 (other sizes, long connection thread and various hole diameters available)
Type of protection	IP 65, IP 68 up to 10 bar (if cable cross-section = hole diameter)
Temperature range	-40 °C to +130 °C

UNI flange HD (exclusively for roof installation, not for underfloor installation)



Material	Zinc die casting, galvanised
Outer dimensions	149 mm x 50 mm
Type of protection	IP 66, Type 4
Temperature range	-20 °C to +80 °C

blueglobe fire protection cable gland with sealing insert made of T80s



Material	Polyamide
Sizes	M16 to M40
Type of protection	IP 68 up to 15 bar, IP 69, Type 4x
Temperature range	-20 °C to +120 °C



What you require

- » Compact air-conditioning units in the driver's cab demand space-saving solutions
- » Large roof-mounted air-conditioning units for the passenger compartment are under continuous load
- » In some cases a great number of power and data cables
- » Tightness of seal
- » Wide temperature range
- » UV resistance
- » EMC shielding

05 | Converters – and how PFLITSCH solutions make them resistant to interference

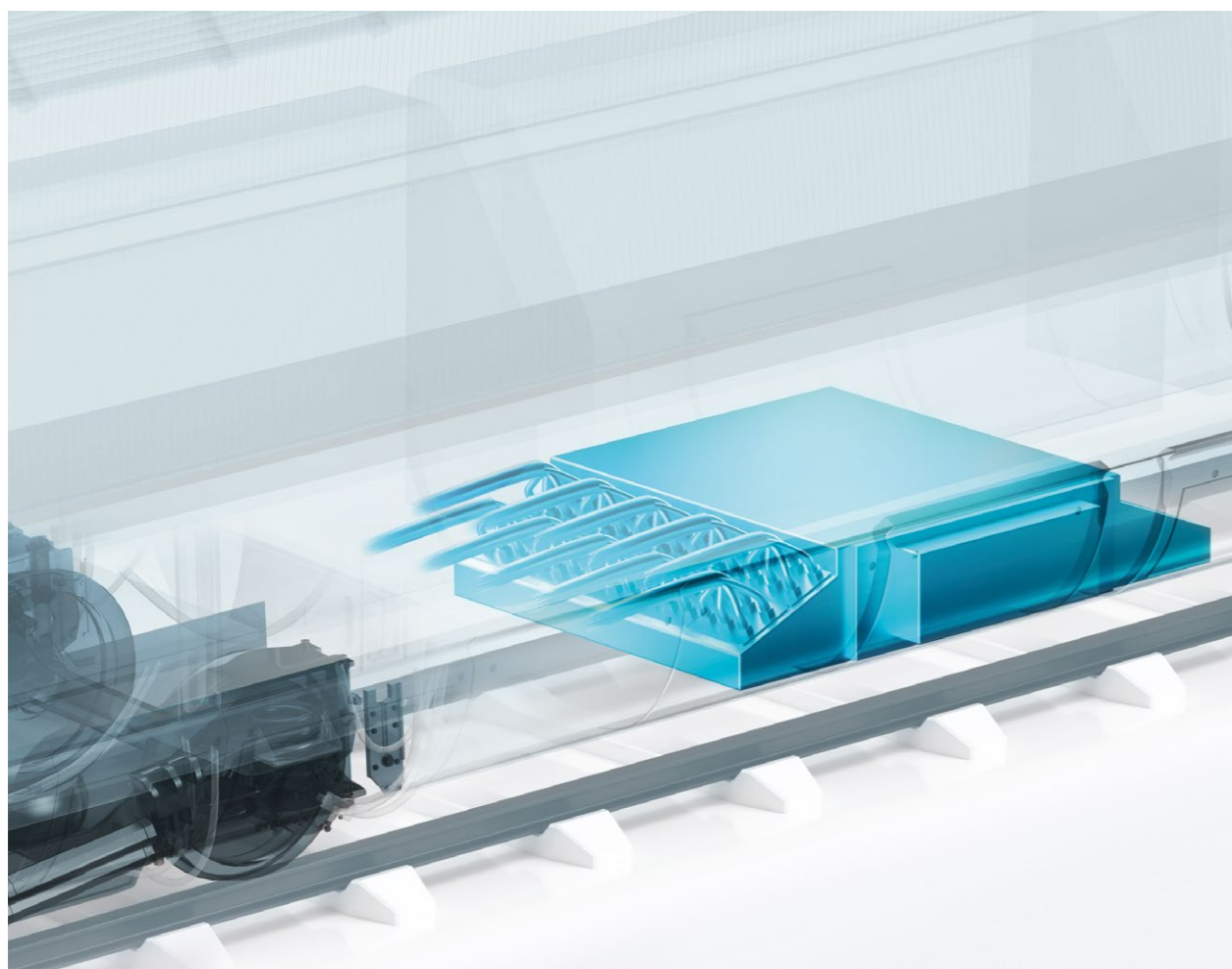

Our product solutions

- » Fire protection cable glands certified for use all around the world
- » Cable glands with single or multiple sealing inserts
- » Made of nickel-plated brass or stainless steel – for optimum corrosion protection
- » EMC shielding optional
- » IP 65, IP 68 up to 10 or 15 bar or IP 69
- » Temperature range: -55 °C to +180 °C



UNI Multiple fire protection cable gland with T80s sealing insert

Material	Nickel-plated brass or AISI 303 (1.4305) stainless steel
Sizes	M16 to M63 (other sizes, long connection thread and various hole diameters available)
Type of protection	IP 65, IP 68 up to 10 bar (if cable cross-section = hole diameter)
Temperature range	-40 °C to +130 °C



blueglobe fire protection cable gland with sealing insert made of S55 or T80s

Material	Nickel-plated brass or AISI 303 (1.4305) stainless steel (All versions also available with long connection thread)
Sizes	M12 to M63 (M16 to M32 available with long connection thread)
Type of protection	IP 68 up to 15 bar
Temperature range	-55 °C to +180 °C (S55), -40 °C to +130 °C (T80s)



blueglobe TRI fire protection cable gland with sealing insert made of T80s

Material	Nickel-plated brass (stainless steel variant on request)
Sizes	M12 to M63 (other sizes and long connection thread available)
Type of protection	IP 68 up to 15 bar, IP 69
Temperature range	-40 °C to +130 °C (S55 sealing insert on request)



UNI EMC Dicht fire protection cable gland with sealing insert made of T80s

Material	brass, nickel-plated
Sizes	M16 to M50 (other sizes available)
Type of protection	IP 68 up to 10 bar
Temperature range	-40 °C to +130 °C (S55 sealing insert on request)
Special feature	Gland body also available with yellow-passivated surface for even better corrosion protection



What you require

- » Feeding of power and data cables into the voltage and frequency converters in the carriage roof or under the floor and protecting them against interference
- » Tightness of seal
- » Vibration resistance
- » Depending on the application, EMC shielding is required

06 | Increase the operational reliability of pantographs – with PFLITSCH products

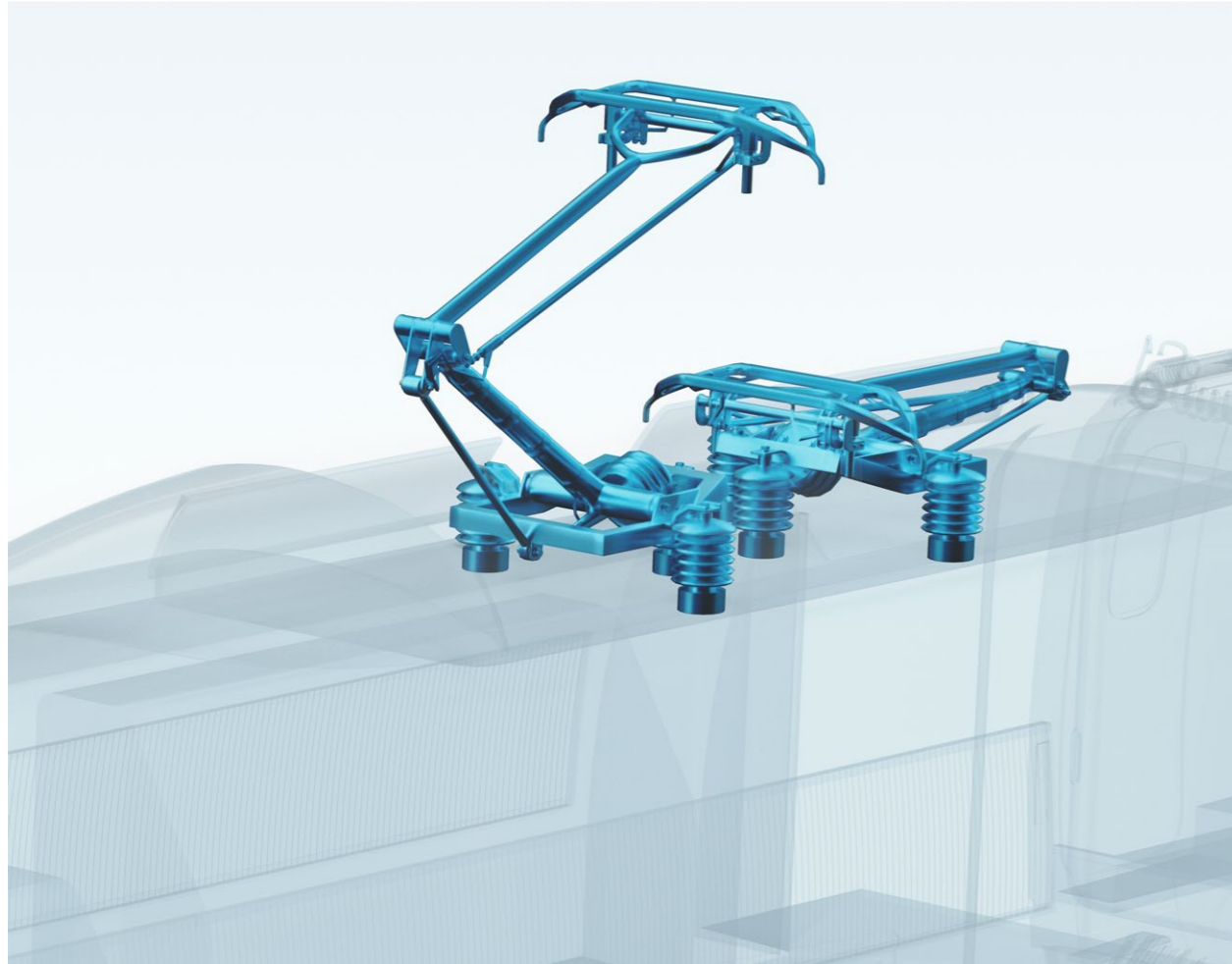

Unsere Produktlösungen

- » Fire protection cable glands certified for use all around the world
- » Solutions for single cables, for multiple cables and for corrugated conduits
- » Temperature range: -55 °C to +180 °C
- » Depending on the product, IP 65 or IP 68 up to 10 bar or even 15 bar



UNI Multiple fire protection cable gland with T80s sealing insert

Material	Nickel-plated brass or AISI 303 (1.4305) stainless steel
Sizes	M16 to M63 (other sizes, long connection thread and various hole diameters available)
Type of protection	IP 65, IP 68 up to 10 bar (if cable cross-section = hole diameter)
Temperature range	-40 °C to +130 °C



UNI Dicht fire protection cable gland with sealing insert made of S55 or T80s

Material	Nickel-plated brass or AISI 303 (1.4305) stainless steel
Sizes	M12 to M63 (other sizes and long connection thread available)
Type of protection	IP 68 up to 10 bar, Type 4x
Temperature range	-55 °C to +180 °C (S55), -40 °C to +130 °C (T80s)

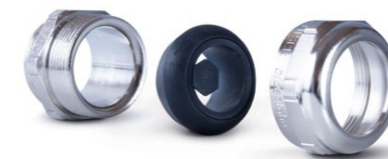

blueglobe fire protection cable gland with sealing insert made of S55 or T80s

Material	Nickel-plated brass or AISI 303 (1.4305) stainless steel (All versions also available with long connection thread)
Sizes	M12 to M63 (M16 to M32 available with long connection thread)
Type of protection	IP 68 up to 15 bar
Temperature range	-55 °C to +180 °C (S55), -40 °C to +130 °C (T80s)



What you require

- » Super-reliable feed-in of cables through the roof of the train into control units
- » Wide temperature range
- » UV resistance
- » Weather resistance
- » Strain relief

07 | Cable entries at intercarriage gangways are made stronger – with solutions from PFLITSCH

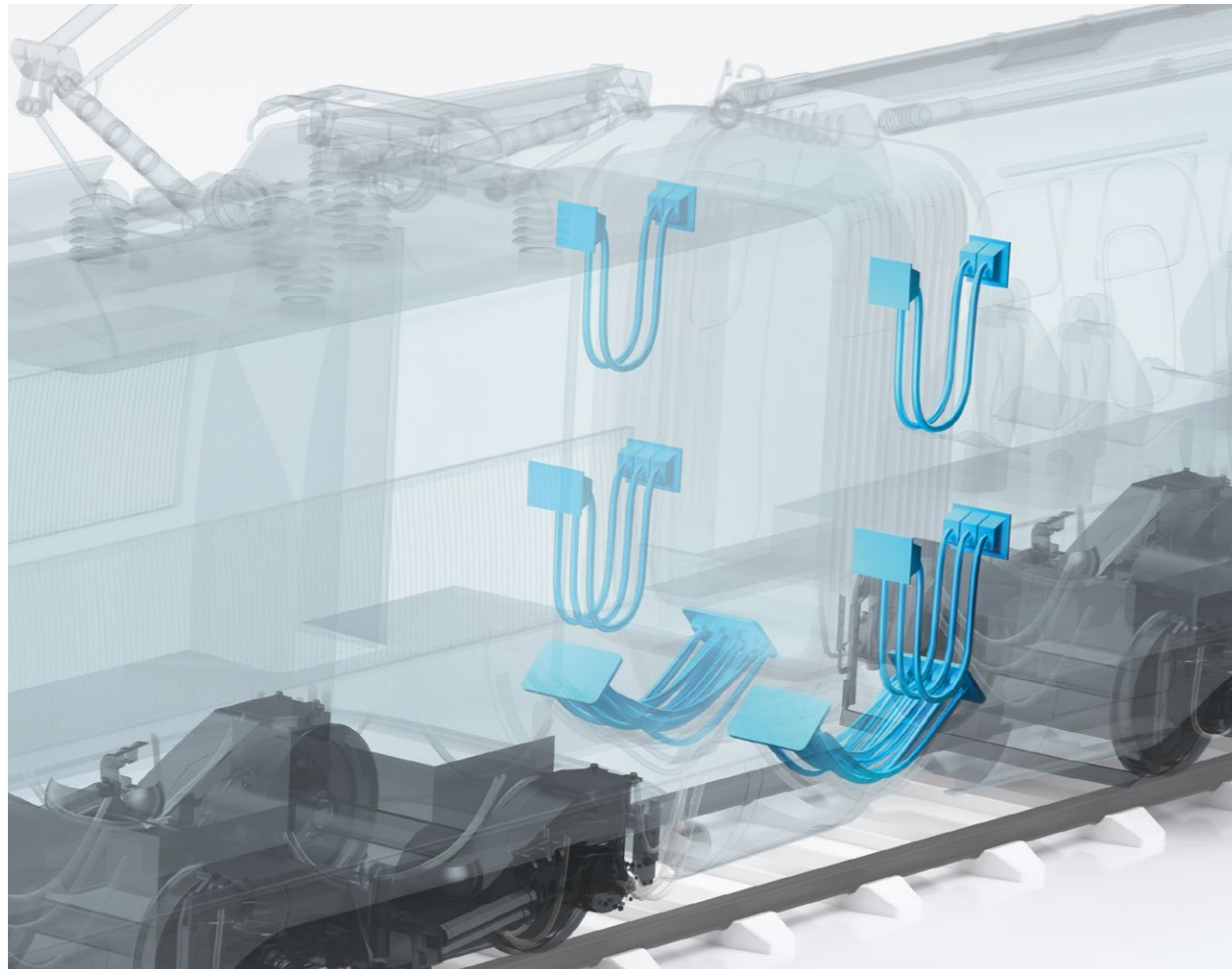

Our product solutions

- » Fire protection cable glands certified for use all around the world
- » Project-specific combination of components from the UNI Dicht and blueglobe ranges
- » Sheathed solutions possible to provide especially high levels of protection
- » Also available with EMC shielding



blueglobe fire protection cable gland with sealing insert made of S55 or T80s

Material	Nickel-plated brass or AISI 303 (1.4305) stainless steel (All versions also available with long connection thread)
Sizes	M12 to M63 (M16 to M32 available with long connection thread)
Type of protection	IP 68 up to 15 bar
Temperature range	-55 °C to +180 °C (S55), -40 °C to +130 °C (T80s)



UNI Dicht fire protection cable gland with sealing insert made of S55 or T80s

Material	Nickel-plated brass or AISI 303 (1.4305) stainless steel
Sizes	M12 to M63 (other sizes and long connection thread available)
Type of protection	IP 68 up to 10 bar, Type 4x
Temperature range	-55 °C to +180 °C (S55), -40 °C to +130 °C (T80s)



What you require

- » In trainsets: inseparable cables with pre-assembled connectors at both ends and complete cable harnesses must be protected in the best possible way at exposed locations.
- » The solution must be robust and space-saving

08 | Routing of cables for various components through roofs and walls

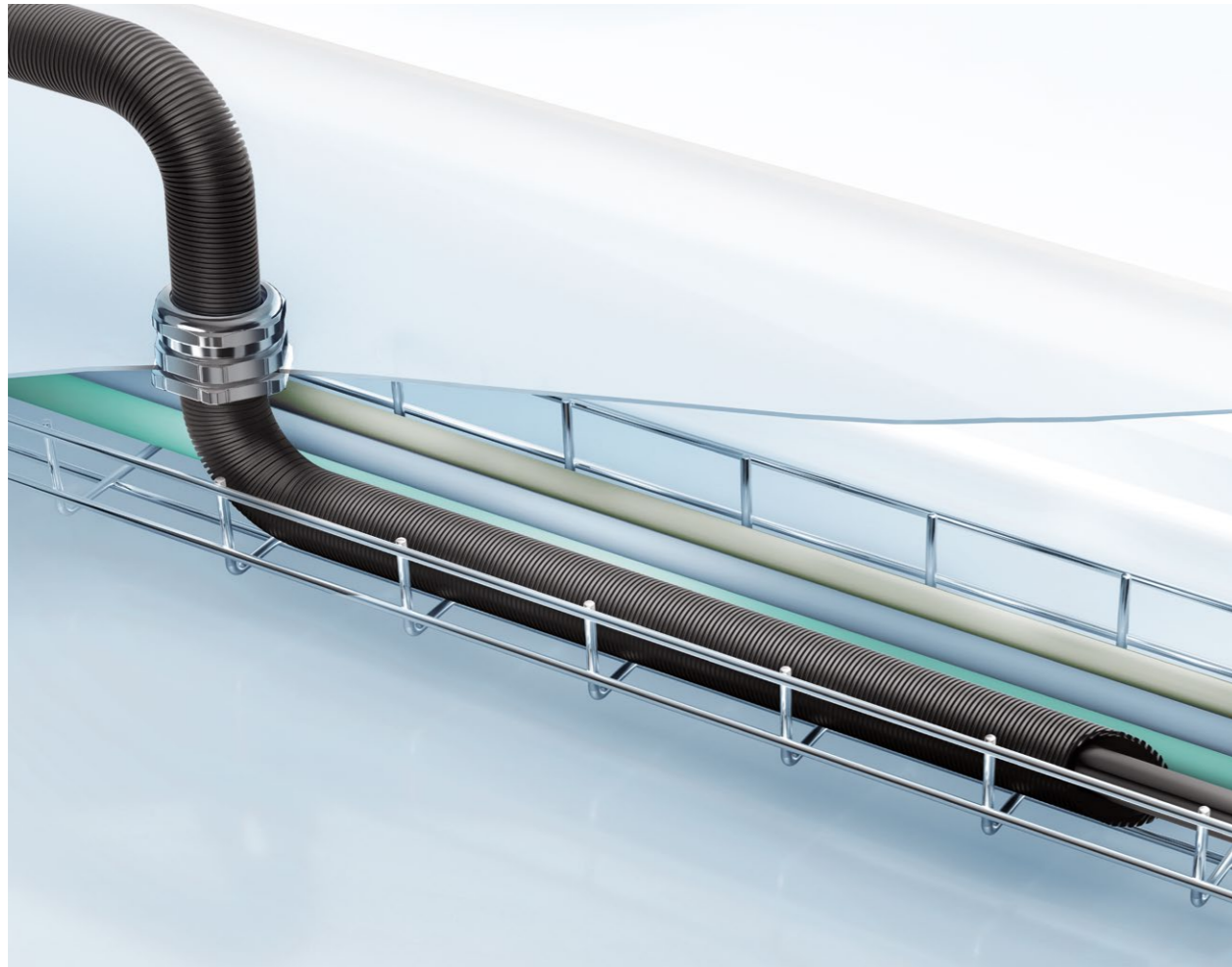

Our product solutions

- » For all components that require cables to be run through the roof or walls of the train: Corrugated conduits and the PFLITSCH corrugated conduit transit
- » Reliable cable protection
- » Tread, pressure and weathering resistance, long-term stability
- » Good flexibility
- » Suitable solution: railway-certified, fire protection corrugated conduit transit for seamless routing of the conduit
- » Installation of pre-assembled corrugated conduits
- » Gland based on the UNI Dicht system, with special corrugated conduit sealing inserts for fine and coarse profile variants
- » Suitable for all PFLITSCH corrugated conduits and all common PMA corrugated conduits
- » Slotted sealing insert that maps the profile of the corrugation exactly for:
 - › tension-resistant assembly
 - › high tightness
- » Easy, safe installation with a flush connection
- » High vibration resistance
- » Excellent cost-benefit ratio
- » Can be combined with other UNI Dicht components, e.g. to seal multiple cables, provide EMC shielding or extra strain relief
- » Available in 6 sizes of corrugated conduit, other sizes on request
- » Optionally, the corrugated conduit can also end with the cable gland and does not have to be led through any further



What you require

- » Safe and efficient routing of power, data and hydraulic lines for various components through the roof or walls of the train
- » Reliable cable protection
- » Tightness of seal
- » Vibration resistance
- » Some applications require additional EMC shielding or strain relief
- » Pre-assembled corrugated conduits must be installed
- » At least protection rating IP 68
- » Flexible and modular solution
- » Easy, safe installation
- » Space-saving and lightweight
- » Price-sensitive solution
- » Conformity with EN 45545-2

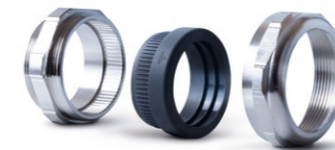

Corrugated conduit transit with sealing insert made of fire protection silicone

Material	brass, nickel-plated
Sizes	M20 to M63
Type of protection	IP 68 up to 10 bar
Temperature range	-55 °C to +180 °C

PFLITSCH Wire-tray Trunking – cable routing to match your particular requirements

Cables used for transmitting data, signals and electricity need to be routed on both the inside and the outside of the train. Due to the different designs of rail vehicle and the limited amount of installation space available, each cable route is subject to different specific requirements.

Many of the standard cable routing solutions from PFLITSCH are already in use around the globe. But we also regularly realise special, customised solutions for domestic and international customers in order to fulfil their special requirements down to the last detail.

With its Wire-tray Trunking, PFLITSCH offers a cable routing solution that can be optimally adapted. In addition to customised and clear cable routing that fits seamlessly into the design, its strengths lie in its robust yet light-weight structure and simple time- and cost-saving installation. In order to separate the multitude of signal lines, power and control cables, additional partition walls can be welded into the Wire-tray Trunking. These also withstand severe and continuous vibration.

Specific requirements can also be met using the other cable routing solutions from PFLITSCH in addition to with Wire-tray Trunking.



What you require

- » Protection of cables run outside/in the roof (both above the passenger compartment and above the driver's cab)
- » Even when vibration levels are high, the cable routing solution must provide reliable protection for the cables
- » Orderly, clear cable routing
- » Cable routing system made of lightweight material
- » Precisely tailored solutions that fit seamlessly into the design and help save on installation times and costs
- » Component assemblies: precisely reproducible components that can be quickly and easily re-ordered in small and also large volumes
- » Solutions for trouble-free retrofitting/ modification of trains in rebuild, conversion and maintenance projects
- » Flexible routing of cables around corners and edges

Our product solutions

- » Robust PFLITSCH Wire-tray Trunking for ideal protection
- » Tailored development of customer-specific solutions (e.g. Wire-tray Trunking with welded-in partition walls)
- » Wire-tray Trunking available in a variety of materials and shapes for maximum cable routing flexibility
- » PFLITSCH assembly service for precisely-fitting, ready-to-install solutions that guarantee an efficient process
- » Typical applications in trains: routing of signal lines, power, energy and control cables



Experience & expertise for more than 100 years

PFLITSCH – experience you can count on

As a manufacturer of innovative solutions for cable entry, cable routing and cable protection, we have **decades of experience in the international railway industry.**

Our perfectly coordinated portfolio of high-quality products always offers you the **right solution for your particular application.** In addition to country-specific standards, our products also meet demanding

manufacturer- and association-specific standards. They are also regularly awarded certifications and re-certifications.

This means you can rest assured that PFLITSCH fire protection solutions are in line with the latest state of the art and suitable for use in all trains.

Join forces with us to get your development package off the ground

You're striving to come up with tomorrow's groundbreaking mobility solutions – you may well find that today's solutions are no longer fit for purpose. As a **competent development partner at your side**, we bring our entire know-how to your project. In addition, you benefit from our unique scope of engineering and degree of vertical integration.

This puts us in a position to **create special customised solutions for the most stringent of requirements** – as demonstrated by numerous projects conducted with renowned vehicle, systems and components manufacturers.

What's more, we anticipate the demands of megatrends such as battery-powered electromobility – whether it be on the road or tracks. To this end, we develop pioneering solutions that not only impress through their universal features, but **also keep pace long-term with the increasing demands of future technologies in terms of safety, durability, EMC and efficiency.**

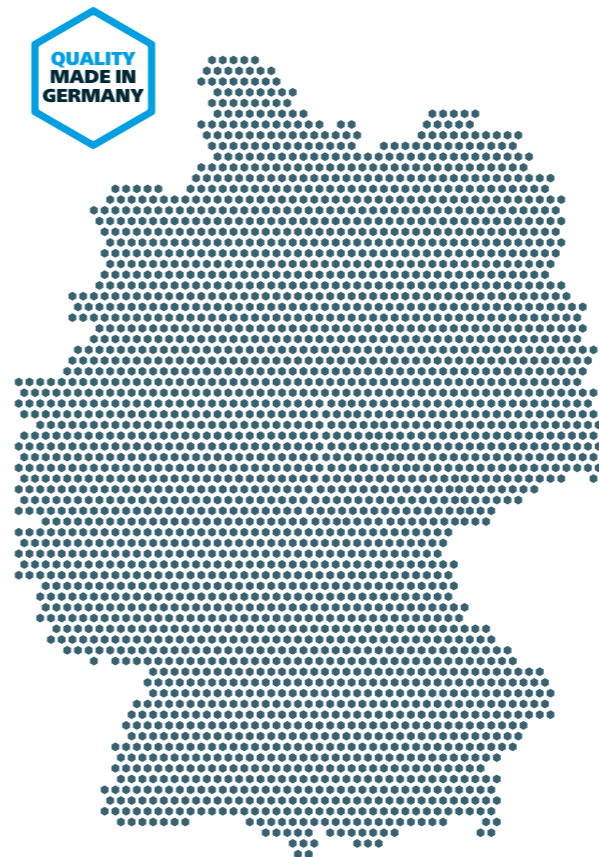

The security of a strong supply chain

We manufacture our products exclusively in our **plants in Germany**, while relying on upstream suppliers also based in the country. This guarantees you not only **consistently high quality "Made in Germany"**. Given the problems in global supply chains, this independence makes us your reliable partner right along the supply chain. That's because you benefit from **guaranteed availability and excellent delivery performance**, which makes you independent of international supply chains and therefore helps to secure your production processes.

PFLITSCH GmbH & Co. KG

Ernst-Pflitsch-Straße 1 · 42499 Hückeswagen · Germany

T +49 2192 911-0 · info@pflitsch.de · www.pflitsch.de

Subject to technical modifications without notice. Errors excepted.

Some of the product names used in this brochure are registered trademarks. You can find an overview of the trademarks owned by PFLITSCH GmbH & Co. KG and that apply at least within Germany at www.pflitsch.de/en/imprint.

All previous and older versions shall cease to be valid upon publication of this brochure. We invite anyone interested in our products to contact us. Should you do so via the communication channels cited in this brochure and on our website, such as our telephone number or e-mail address, we ask you to take note of our declaration on data protection under the header "Privacy Policy" on our website www.pflitsch.de/en.

Kompetenzbroschüre Bahn GB | 09.2022 | 151651 | 151656+